



www.lscns.co.kr
Busduct System

04386, 18th Fl LS Yongsan Tower 92 Hangangdaero Yongsan-gu, Seoul
Tel. 02-2189-8884 Fax. 02-6969-5424

©2022 LS Cable & System Ltd. All right reserved.
LS Cable & System holds the copyright of all data used in the present catalog. All data used in this catalog is protected by the copyright. It will be distributed by the license that limits the use, copy and distribution of data. It is prohibited to use any part of the present catalog for any type or means without the prior written approval by LS Cable & System. Products listed in this catalog may be subject to change without prior notice.

CR-LV/MV

Total Busduct Solution for Reliable and Efficient Energy Distribution

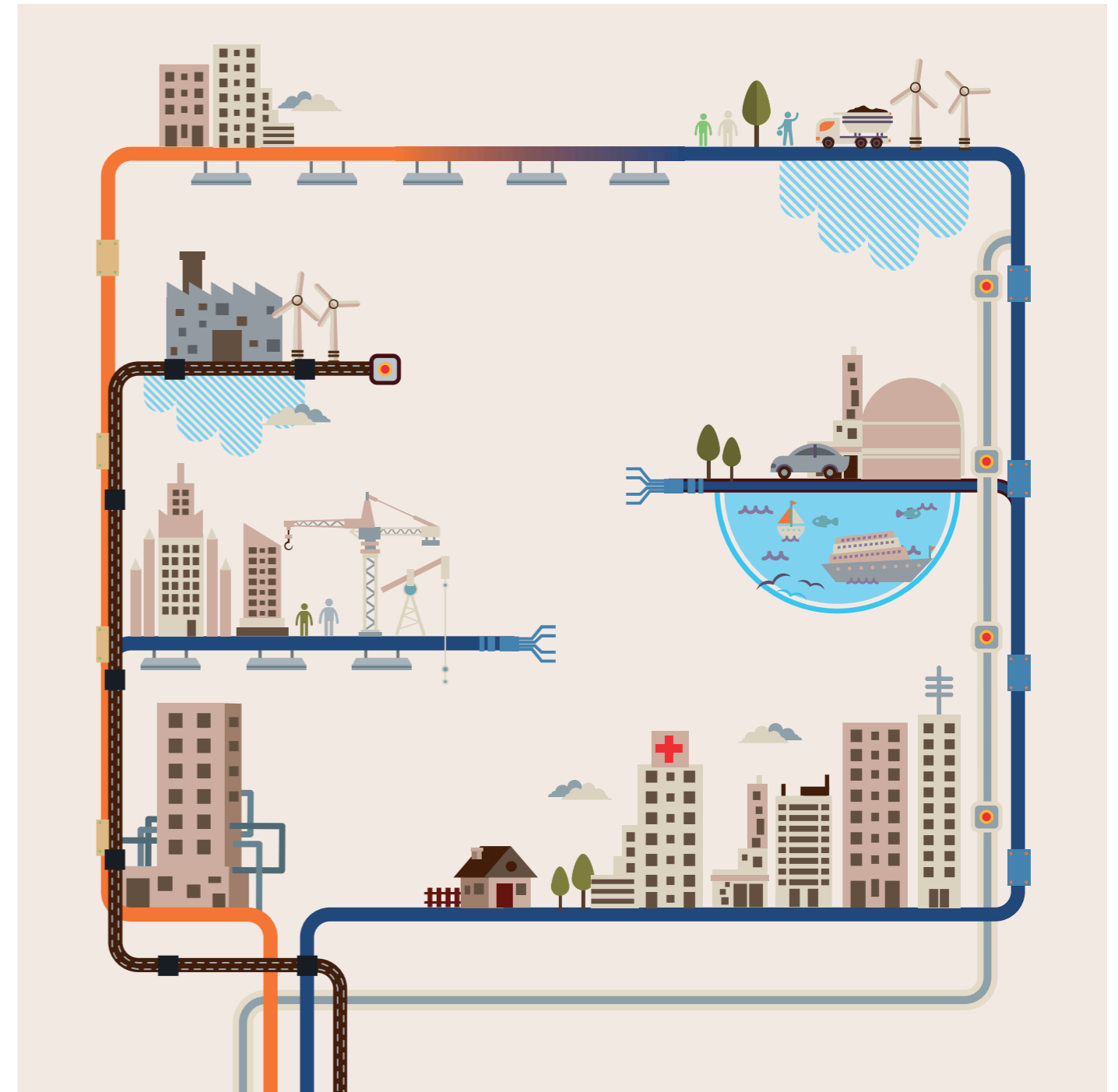



Busduct System Solution of LS Cable & System



Building

On account of the advantages of the busduct of LS Cable & System such as high-capacity current transmission, efficient space utility, and convenient construction, its application has been expanded continuously for skyscraper, office building, knowledge-industry center and apartment factory.



Plant

The system is equipped with Full Line Up of NSPB to cover 36kV and CAST RESIN to support the customized design. It is available to use them for both electricity room and power trunk lines. Especially, the system is equipped with the advantage of a real-time monitoring that uses the monitoring system of temperature and power.



Data Center

According to the relocation and extension of load and the severe change of capacity in the data center, the excellent flexibility and expandability and easy follow-up management of the busduct has been emerged as the best alternative to supplement the problem of existing power trunk line system.

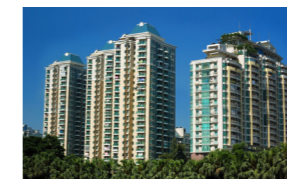

Apartment

Compared to the enlargement of load capacity through the increased use of power by each household, the use of Busduct and Multi Box has been increased due to the decreased design area of EPS room.



Hospital

The stable power supply in a hospital is very important role that is directly connected to the life of patients. According to the systemization of hospital complex and the enlargement of hospital equipment, the stability of power supply and load has caused the rapid increase of demand for Main Power Line.



Airport

In order for the stable power supply to the airport terminal, a high voltage Busduct is applied to power service, substation and distribution line, and a low voltage Busduct from the luggage control tower to the general commercial building to provide an optimum customized solution that fits the use purpose.

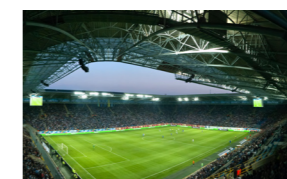

Stadium

Stable power supply is available for high capacity current transmission and various loads. The use of eco-friendly and economic Busduct has been expanded.

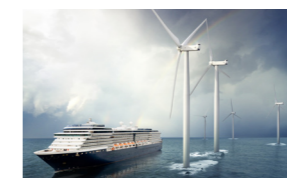

Marine & Wind

The system meets customers' demand for compactness and light weight. It also retains the excellent aseismatic feature to endure vibration. It is available to utilize the monitoring system for temperature and power and to check in real-time the abnormal condition of buildings for the stable operation of equipment. Its demand has been continuously increased to the expanded demand of new renewable energy.

Busduct Product Lineup of LS Cable & System

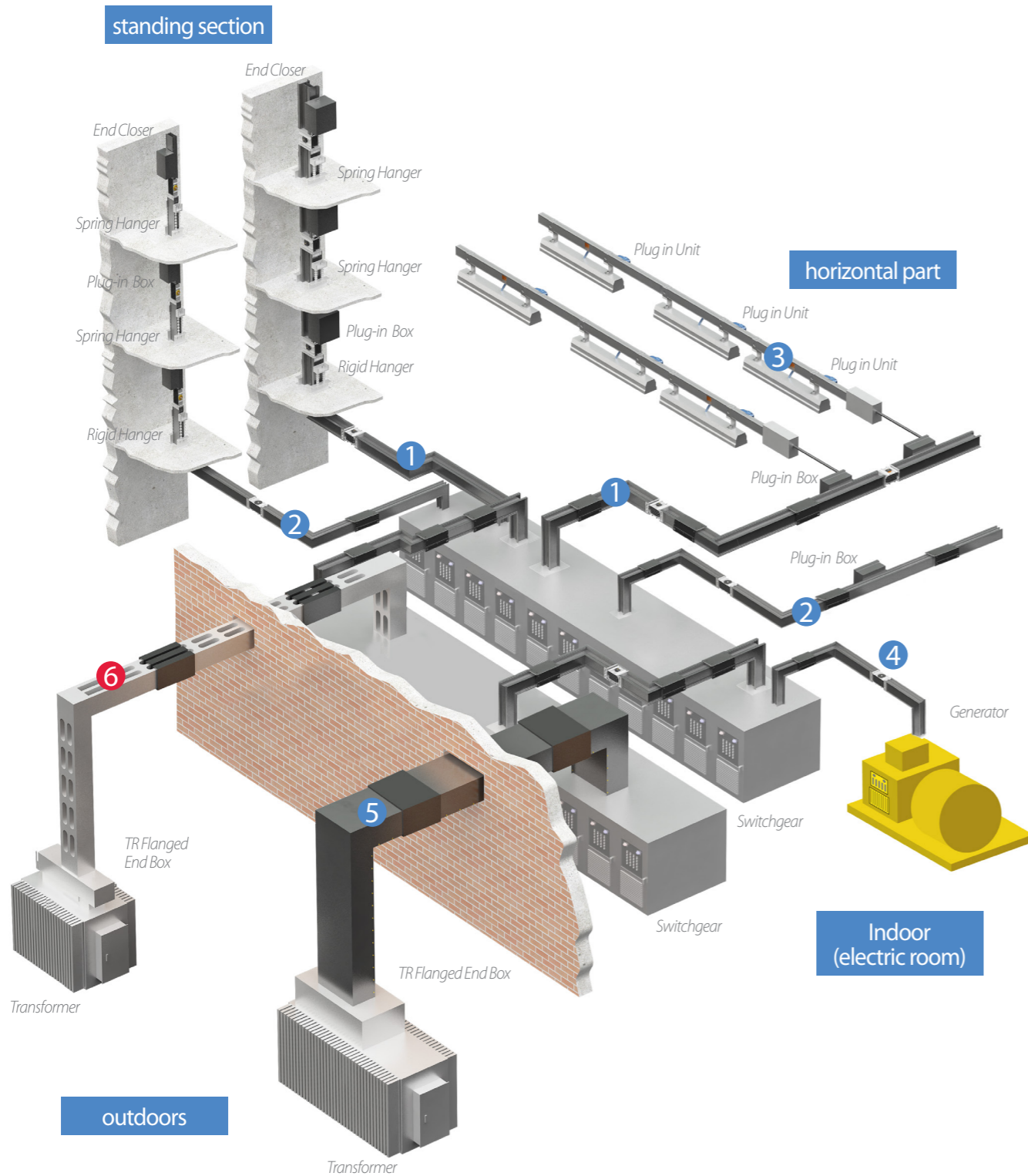

Busduct of LS Cable & System is furnished with various products from small capacity (25A~63A) LT-way to high capacity (630A~7500A) E-Series to send proper necessary current at the composition of a factory and a power distribution system. In addition, the system provides customized engineering service for the diverse application to the product of air insulation type that doubles the stability and to the cast resin product applicable to many environments of high temperature, high humidity and much dust.

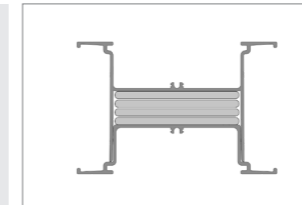

Ez/Ex/Ef-way, lz/lx/lf-way

Applicable to sandwich type (PET Film, Epoxy Coating, MICA) / AL Extrusion Housing / Basic IP54 / Joint Kit
 - Products with low voltage below AC 1000V from 630A to 7500A
 - Used widely for general type

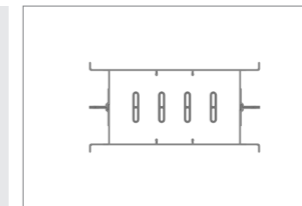
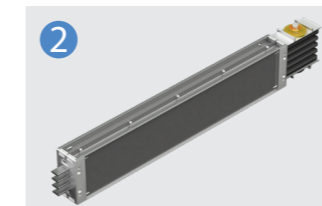

Mini-way

Applicable to Air insulation type / AL Extrusion Housing / Basic IP54 / Joint Kit
 - Products with low voltage below AC 1000V from 160A to 800A
 - Small size trunk line with many load branches (Vertical area of building, data center, assembly plant)

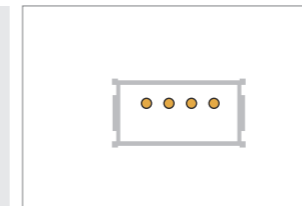
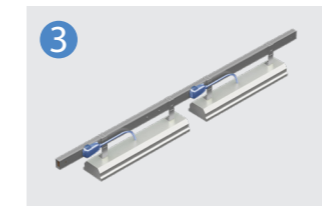

LT-way

Applicable to Flat Wire type / PVC extrusion insulation on copper conductor / AL Extrusion Housing / Various plugs / Connection Brush (Available to install in live wire condition)
 - Products with low voltage below AC 690V from 25A to 63A
 - Trunk line for small size equipment such as lighting and FFU

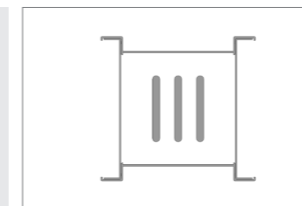
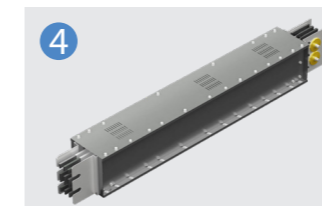

MS/Wind-way

Air insulated compact NSPB type / Joint part ONE-Bolting type
 - Products with low voltage below AC 1000V from 1000A to 6300A
 - NSPB and sandwich type Hybrid
 - Specialized for vessels requiring stability / Wind power / Vibration

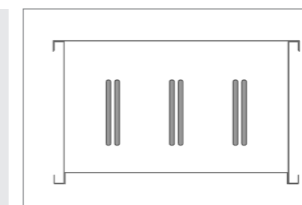
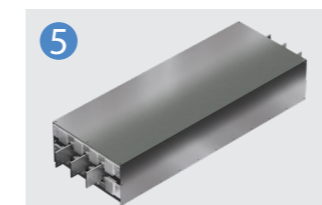

NSPB-LV/MV

Air insulation type / Product that isolates the insulated conductor for each phase / Select AL, STS, Steel housings / Indoor type / Outdoor type
 - NSPB-LV: Products with low voltage below AC 1000V and below 4000A
 - NSPB-MV: Products with high voltage below AC 36kV and below 4000A
 - Plant required of high stability

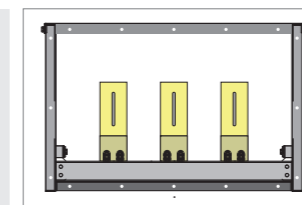
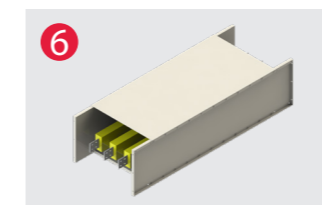

CR-LV/MV

Cast Resin type / IP 68 / Molding with insulated epoxy between conductors / Epoxy molding on the joint part after its installation
 - CR-LV: Products with low voltage below AC 1000V from 630A to 7500A
 - CR-MV: Products with high voltage below AC 36kV and below 5000A
 - Safest type Busduct for the plant required of high stability

Overview

The CR-way

The LS C&S CR-way is available from a low voltage of AC 1000V or less, up to a high voltage of 36kV. It is suitable for current capacities between 630A to 7500A for low voltage and 1250A to 5000A for high voltage products. The epoxy resin molding performs itself as insulation and housing with an IP68 rating. The CR-way is mainly suitable for plants and factories where large capacity of power is required. It is an ideal distribution wiring system for outdoors, humid and dusty areas and any place where chemicals are frequently used.



Anticorrosion

The epoxy insulation of the CR-way is highly resistant to erosion and corrosion. Additional housing can be applied to maximize stability depending on the environment.



Fire Proof

The CR-way comes with fire resistance efficiency as a standard feature, and it is designed to prevent flames from spreading.



Aseismic Structure

The CR-Way meets aseismic standard of Zone 4 providing stable power supply even in seismic environment.



Water proof & Dust proof

The CR-way comes with a standard IP68 rating, and is protected completely against water and particles. It is safe to use in an inadequate environment.



Explosion Proof

The CR-way is designed to be completely molded by insulation, and this design ensures safety use of the product near inflammable steam and gas, and dusty environment with an explosive atmosphere.



Eco-friendly

The CR-way has acquired an RoHS certification, and only uses components without hazardous substances such as lead, cadmium, mercury, chrome, PBBs and PBDEs.

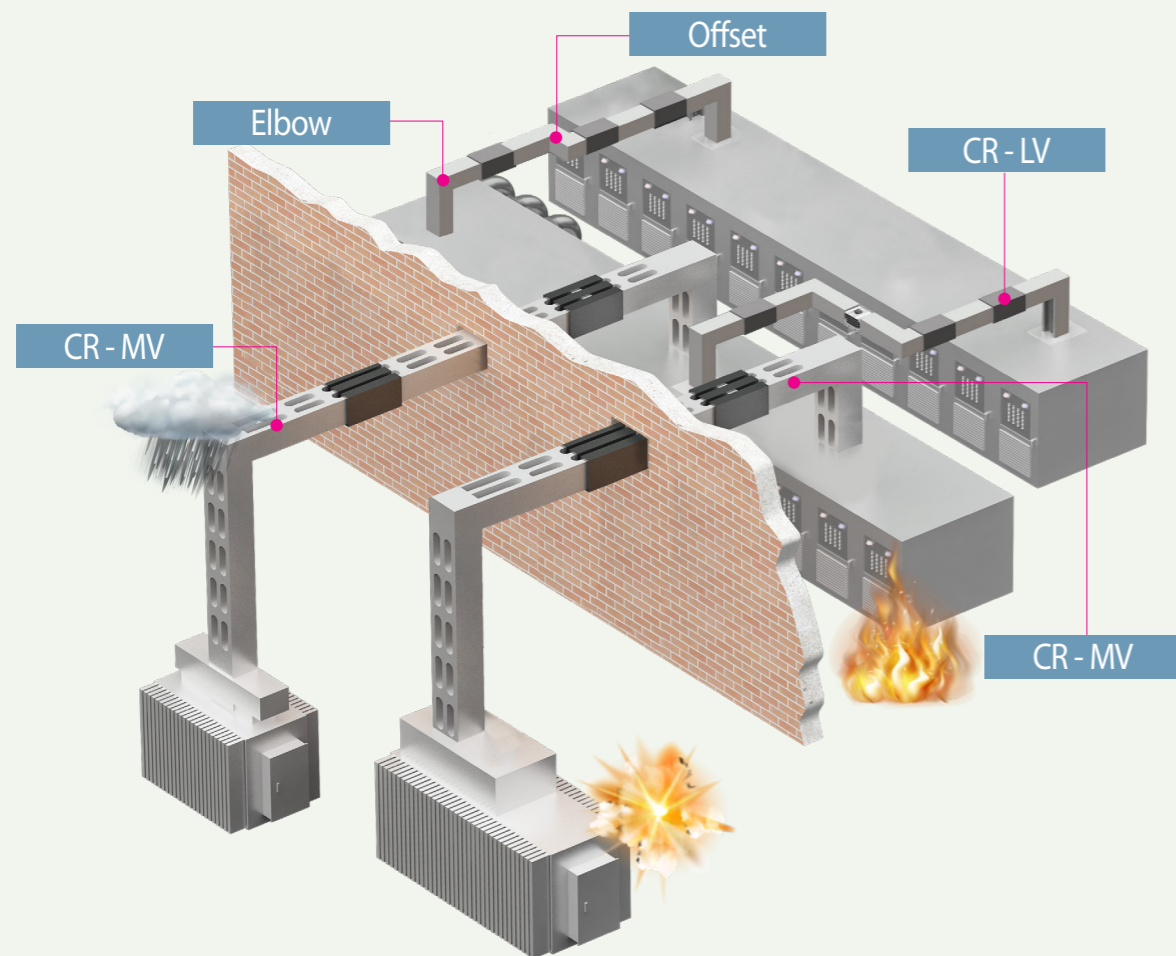

IP Code (Degree of Protection)

IP Code is an international protection degree code provided by IEC 60529(Degree of Protection Provided by Enclosure-IP Code)

The standard feature of the CR-way comes with a standard IP68 rating. The CR-way is suitable for humid and dusty areas, chemical plants and areas where condensation may occur (exposed section between indoors and outdoors).

IP 6 8

Solid Particle Protection

- 0 No Protection
- 1 Protection against 50mm diameter solid particles. (back of a hand)
- 2 Protection against 12mm solid particles. (fingers)
- 3 Protection against 2.4mm solid particles. (tools or thick wires)
- 4 Protection against 1mm solid particles. (tools or most wires)
- 5 Protection against dust.
- 6 Complete protection against dust.

Liquid Ingress Protection

- 0 No Protection
- 1 Protection against falling drops of water.
- 2 Protection against falling drops of water with an enclosure tilted at a 15degree angle from a vertical line
- 3 Protection against spray sat a 60degree angle from a vertical line
- 4 Protection against water splashed from all directions.
- 5 Protection against low pressure jets of water from all directions.
- 6 Protection against strong jets of water from all directions.
- 7 Protection against the effects of immersion between 15.0 centimeters and 1.0 meter.
- 8 Protection against longer periods of immersion under pressure.

IK 1 0

Degree of Protection against mechanical Impact

- 1~5 [Impact < 1 Joule]
- 6 Equivalent to impact of 500g mass dropped from 20cm above impacted surface. [Impact 1 Joule]
- 7 Equivalent to impact of 500g mass dropped from 40cm above impacted surface. [Impact 2 Joule]
- 8 Equivalent to impact of 1.7kg mass dropped from 29.5cm above impacted surface. [Impact 5 Joule]
- 9 Equivalent to impact of 5kg mass dropped from 20cm above impacted surface. [Impact 10 Joule]
- 10 Equivalent to impact of 5kg mass dropped from 40cm above impacted surface. [Impact 20 Joule]

CR-LV-II

LS Cable & System Busduct System Catalogue

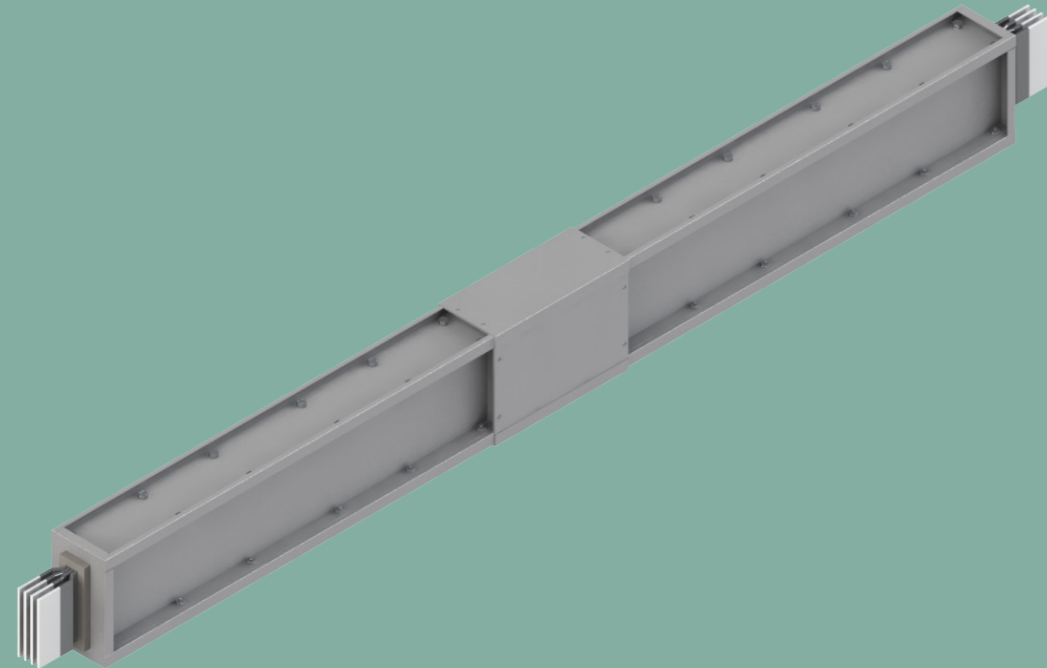

Contents

I. General Data	9
II. Component	
- Feeder	11
- Flanged End	12
- Fittings	13
- Hanger	14
- Etc	15
III. Technical Data	
- Impedance	16
- Voltage Drop	16
- Temperature Rise	17
IV. Install Information	18

I. General Data

Basic Structure

Each conductors of CR-LV-II is insulated with Class B (130°C) epoxy powder coating (fluidized bed epoxy coating method: over 500um) and placed in metal housing. The space between conductors and metal housing is molded with epoxy resin providing improved electrical stability and durability compared to sandwich type busduct especially in terms of protection against water, dust, fire and explosion. In addition, it improved insulation performance, protection against mechanical impact and reduced the weight of the product allowing easier installation compared to other typical type cast resin busduct without metal housing.

Applicable Standard: IEC 61439-6

Applicable Environment: Ambient temperature from -15°C to 35°C with humidity level less than 95%.

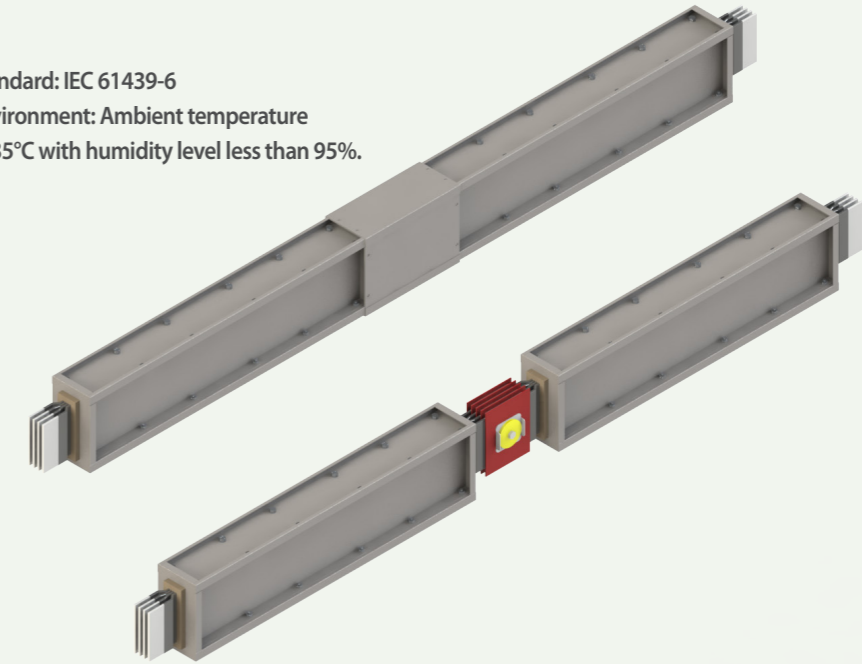

Configuration

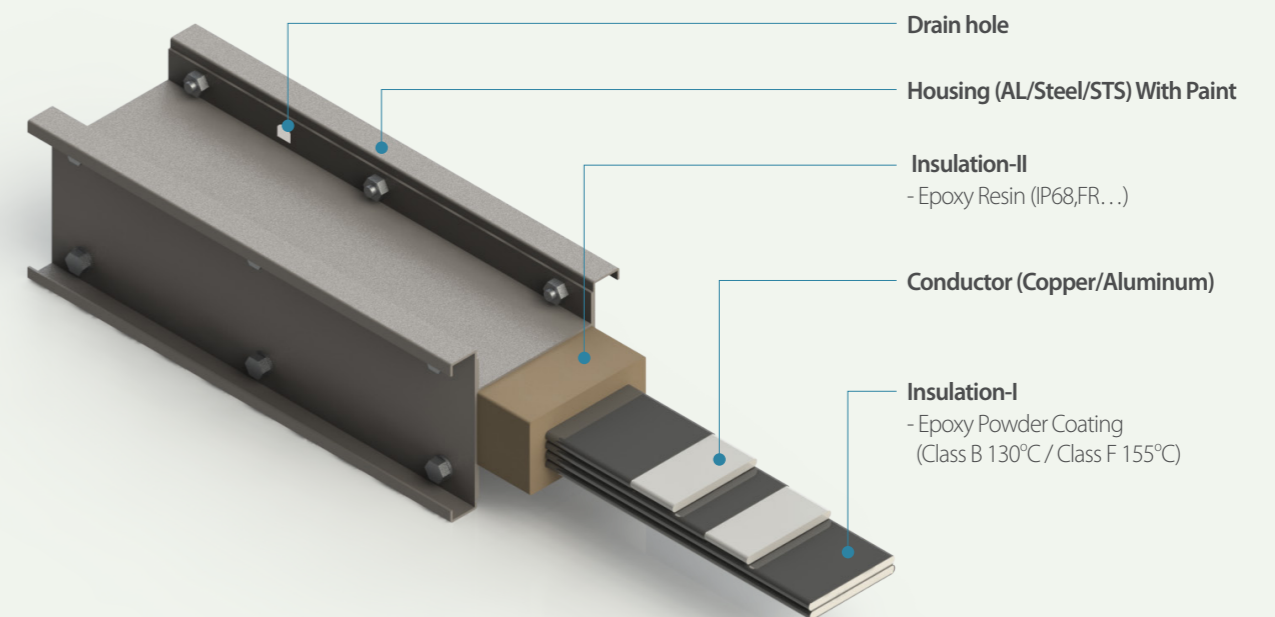

Joint Kit

The CR-way uses a joint kit method.

FEATURE

Both joint plates of the joint kit and the conductors are tin plated. (A silver plated option is available.) It prevents discoloration and corrosion of the joint plates. In order to ensure easy maintenance and reliability, double-headed bolts and visible labels are used to check the application, and a disc spring allows an even connection of the contact surface.

Double Head Bolt

Double-headed bolts are used to ensure a proper torque level when installing the joint kit. If a torque wrench applies a pressure of 700 to 1000kgf-cm to the outer bolt head, the head of the outer bolt and there tag attached to it will break off on its own. Thus, it allows visual inspection for the proper application of the bolts at the connection.

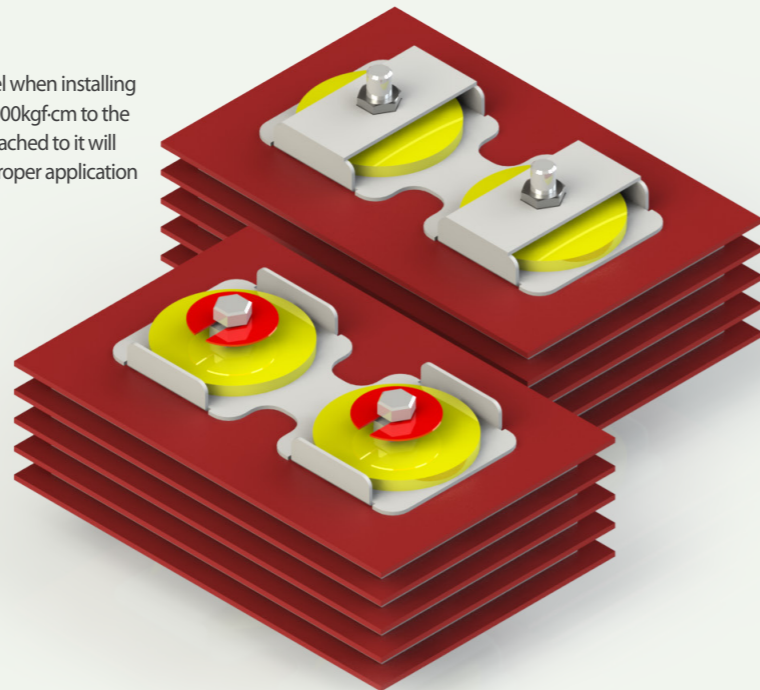

The number of double-headed bolts required for each joint kit specifics

Number of DH bolts		1	2	4	6
Ampere (A)	AL	630, 800, 1000, 1250	1600, 2000, 2500	3200, 3600, 4000	5000, 6300
	CU	630, 800, 1000, 1250, 1600, 2000	2500, 3200, 3600, 4000	5000	6300, 7500

! Precaution

Be sure to clean the interior of the connections prior to installation. Use caution not to twist the joint kit while inserting it, and after it is inserted. An excessive pressure during installation may break the kit. Make sure that the double-headed bolts and red tags are cut off. If a proper torque is not applied at the connection, it may cause heat during operation.

Feeder

Although the standard length of the LS C&S CR-LV Busduct feeder is 3 meters, it can be adjusted to the installation environment, or on request.

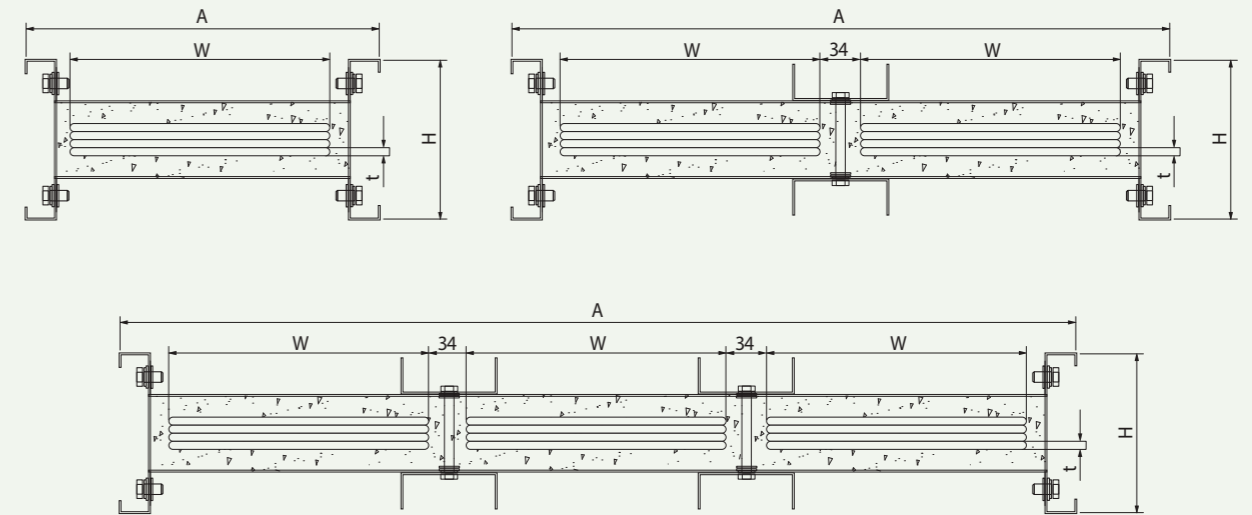

Ampere(A)	Dimension(mm)			Weight(kg/m)					
	t	W	A	3W	3W+50%E	4W	4W+50%E	4W+100%E	
AL	6.35	630	41	121	21.8	22.0	22.8	23.1	23.8
		800	62	142	25.6	25.9	26.8	27.2	28.2
		1000	86	166	29.7	30.1	31.3	31.8	33.1
		1250	108	188	33.6	34.0	35.5	36.1	37.6
		1600	164	244	43.6	44.3	46.4	47.3	49.4
		2000	210	290	51.8	52.6	55.3	56.4	59.0
		2500	(2)126	386	67.1	68.2	71.7	73.1	76.6
		3200	(2)164	442	80.8	82.2	86.5	88.4	92.7
		3600	(2)184	482	87.9	89.5	94.2	96.3	101.1
		4000	(2)210	534	97.7	99.6	104.9	107.3	112.7
5000	(3)184	700	128.7	131.1	138.3	141.5	148.6		
6300	(3)210	778	142.6	145.3	153.3	156.8	164.9		
CU	6.35	630/800	41	121	27.1	28.1	29.7	30.9	32.5
		1000	57	137	31.8	33.2	35.3	36.9	39.0
		1250	73	153	36.9	38.9	41.5	43.5	46.1
		1600	108	188	47.7	50.5	54.3	57.3	61.0
		2000	145	225	59.0	62.7	67.6	71.6	76.5
		2500	195	275	73.9	78.8	85.4	90.6	97.1
		3200	(2)108	330	89.4	95.1	102.6	108.8	116.3
		3600	(2)126	366	100.1	106.7	115.3	122.4	131.1
		4000	(2)146	404	111.5	119.1	128.9	137.0	146.9
		5000	(2)195	504	143.6	153.8	166.9	178.0	191.1
6300	(3)164	640	182.6	195.5	212.1	226.1	242.7		
7500	(3)195	733	210.9	226.1	245.7	262.0	281.6		

* H : AL - 140mm (3W+GE, 3W+50%E, 4W+GE, 4W+50%E) / 160mm (4W+100%E)
 CU - 140mm (3W+GE, 3W+50%E, 4W+GE) / 160mm (4W+50%E, 4W+100%E)

Hanger

Both horizontal and vertical hangers are available for the CR-LV-II depending on the installation environment.

Horizontal Hangers

The standard horizontal installation method of the CR-LV-II requires two supports for each product. The standard 3 meter busducts are designed to be installed at 1.5-meter intervals, and the space between the hangers should not surpass 2 meters at the most. (Please contact the design team for further information.)

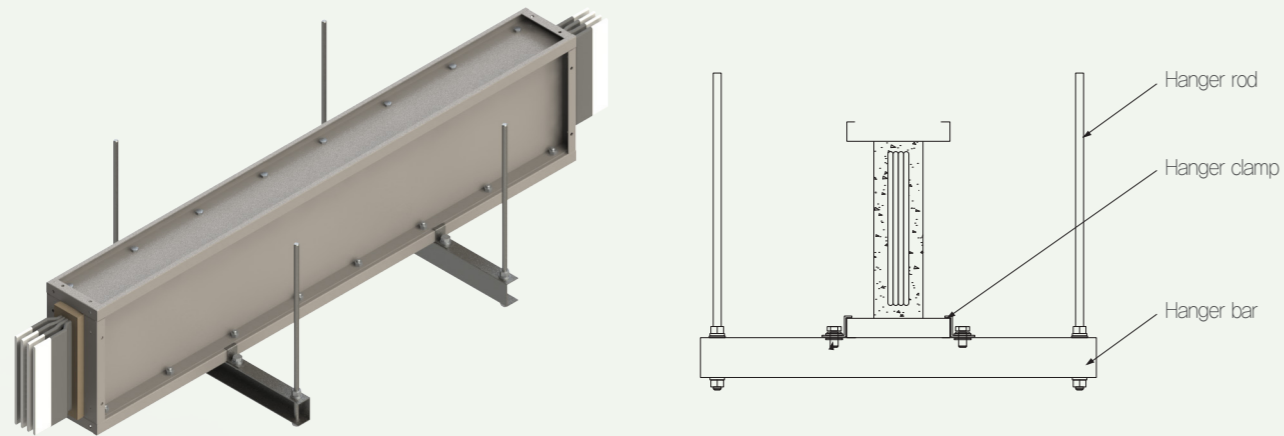

Vertical Hangers

For vertical installation of The CR-LV-II, install the vertical hangers first, and fix the Busducts on the hangers for better support.

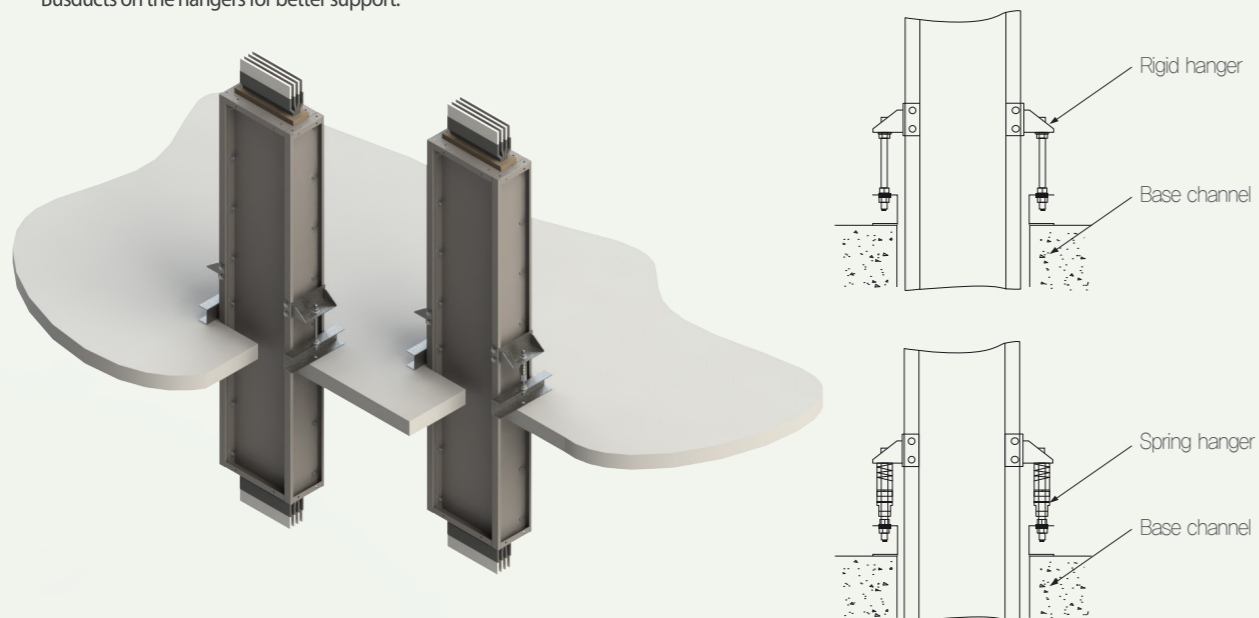

Etc.

Wall Flange

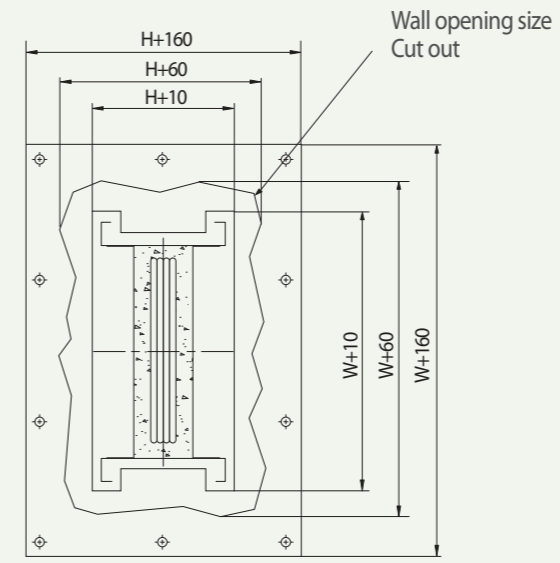

A wall flange is used to seal the gaps where busduct penetrates such as walls, ceilings and floors during installation. (Glass wool and fire forms can be provided as an option).

- W: The Width of the product
- H: The Height of the product

Floor Opening

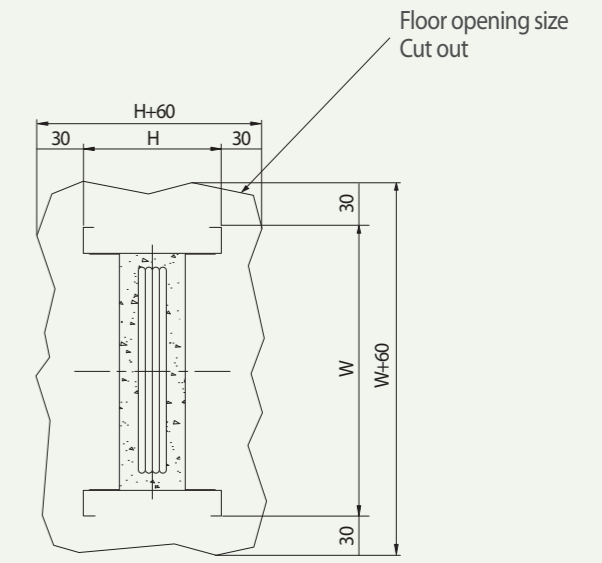

- W: The Width of the product
- H: The Height of the product

The required minimum distances from a wall for heat dissipation and maintenance

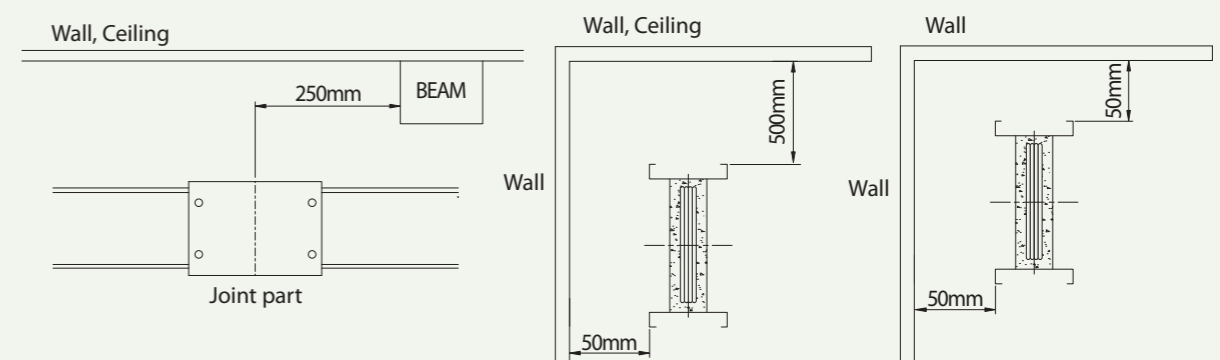

Technical Data

Impedance and Voltage Drop

The formula to measure the voltage drop of a busduct is shown below. The impedance and voltage drop values for aluminum and copper conductors are shown in the table below. The values listed are measured between upper and middle lines at 60Hz. For a 50Hz installation, multiply the reactance (X) by 0.83.

$$V_d = I \times \sqrt{3} (R \cos\theta + X \sin\theta)$$

V_d = Voltage Drop [V] · I = Rated road amperes [A] · R = Line Resistance [Ω] · X = Line Reactance [Ω] · $\cos\theta$ = Power Factor · $\sin\theta$ = Reactive Factor

$$\text{Actual Voltage Drop} = \alpha \times V_d \times \frac{\text{Actual Loaded Current}}{\text{Rated Load Current}} \times \frac{\text{Actual Length of the line (m)}}{100m}$$



Ampere (A)	Impedance $\times 10^{-5} \Omega/m$ ($= 10^{-3} \Omega/100m$) (60hz)			Voltage Drop (V/100m)				
	R	X	Z	0.7	0.8	0.9	1	
AL	630	14.72	7.11	16.34	16.78	17.50	17.83	16.06
	800	9.78	5.44	11.19	14.87	15.37	15.49	13.55
	1000	7.14	4.30	8.34	13.98	14.37	14.38	12.37
	1250	5.76	3.61	6.80	14.32	14.67	14.64	12.47
	1600	3.92	2.57	4.69	12.70	12.98	12.89	10.87
	2000	3.14	2.09	3.77	12.78	13.04	12.95	10.89
	2500	2.68	1.78	3.21	13.60	13.88	13.78	11.58
	3200	2.13	1.40	2.55	13.81	14.10	14.00	11.79
	3600	1.58	1.26	2.03	12.54	12.63	12.32	9.88
	4000	1.39	1.12	1.78	12.26	12.34	12.03	9.62
	5000	1.06	0.87	1.36	11.75	11.81	11.49	9.14
	6300	0.92	0.76	1.20	13.00	13.06	12.70	10.08
CU	630	8.57	7.11	11.14	12.09	12.14	11.80	9.35
	800	8.57	7.11	11.14	15.35	15.41	14.98	11.87
	1000	6.42	5.77	8.63	14.91	14.88	14.36	11.11
	1250	5.09	4.85	7.03	15.21	15.12	14.50	11.02
	1600	3.56	3.61	5.07	14.06	13.90	13.25	9.87
	2000	2.74	2.85	3.96	13.71	13.53	12.86	9.50
	2500	2.12	2.22	3.07	13.30	13.12	12.46	9.18
	3200	1.94	2.03	2.81	15.59	15.38	14.60	10.76
	3600	1.70	1.78	2.46	15.34	15.14	14.38	10.61
	4000	1.51	1.57	2.18	15.08	14.89	14.15	10.46
	5000	0.88	1.20	1.48	12.72	12.30	11.35	7.60
	6300	0.79	1.08	1.34	14.44	13.95	12.87	8.58
7500	0.58	0.82	1.01	12.91	12.45	11.47	7.59	

Short Circuit Strength

The short circuit strength of the CL-LV-II has been tested as specified in IEC 61439-1, 6

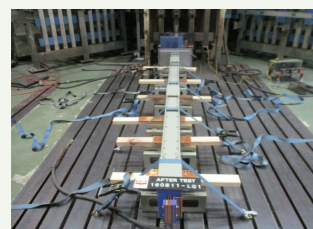

Ampere (A)	630	800	1000	1250	1600	2000	2500	3200	3600	4000	5000	6300	7500
AL	1sec	24	40	50	50	80	80	80	80	100	100	100	-
	3sec	14	23	29	29	46	46	46	46	58	58	75	-
CU	1sec	40	40	50	50	80	80	80	80	100	100	100	100
	3sec	23	23	29	29	46	46	46	46	58	58	75	75

Temperature Rise

The temperature rise limit is an important factor which determines the performance of the busduct. CR-LV-II is designed with maximum temperature rise values of the housing to be within 55K when it is operated with a rated current as per IEC 61439-2 and 6 (former standard of IEC 60439-1 and 2).

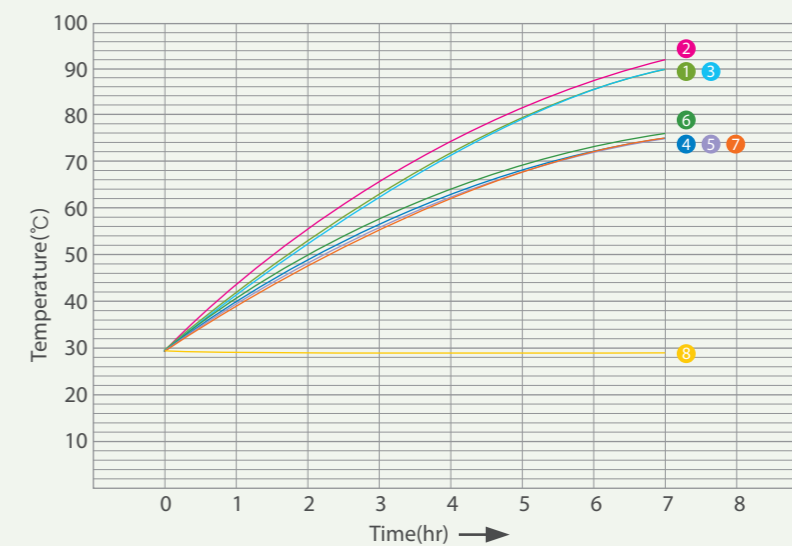
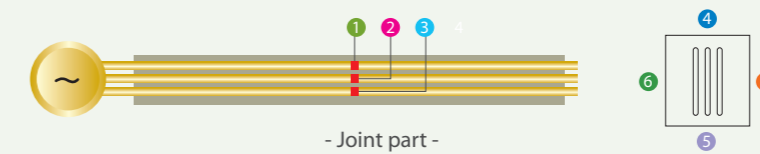

Classification	1	2	3	4	5	6	7	8
Sensor Location	Joint Conductor			Exterior of Epoxy				Ambient Temperature
Temperature Rise Value	61K	63K	61K	46K	46K	47K	46K	29.4°C

CR-LV-II Joint Kit Installation

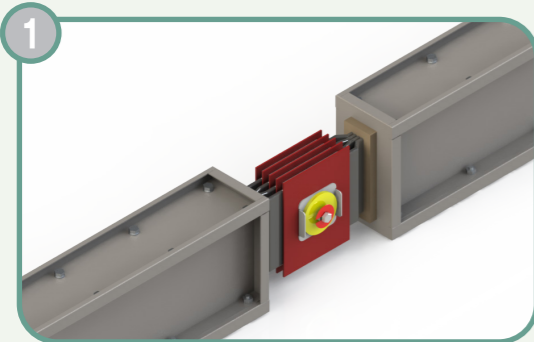

Before connecting the busducts, be sure to align them at the top and the bottom and the left and the right as well as horizontally and vertically. (This applies for joint connection of the horizontal and vertical ducts.) Make sure that the joint kit is not tilted. Be sure that the surface is clear of particles before connecting them.

Checklist

- The alignment of the busducts.
- The surface of the joint must be clear of dust or particles

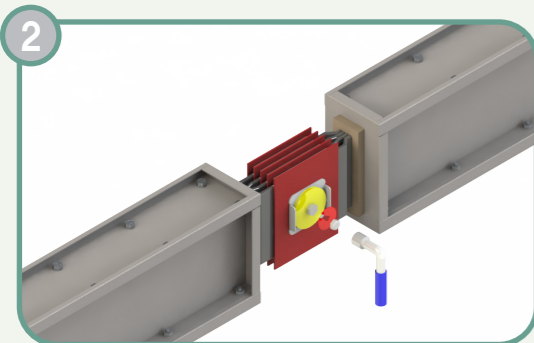

Using a torque wrench, slowly tighten the exposed bolt head of a double head bolt. Connect the busducts temporarily first, and check the function of the insulation (100MΩ or higher) by checking the insulation resistance. Make sure the insulation is working normally before breaking off the double-head bolt head. The double-head bolt head is designed to break off at 800~1000Kgf-cm, therefore tighten the exposed head until it breaks off. Once the exposed head and the red tag attached to it have been cut off, the state of the joint connection should be visible, which means they are properly connected.

Checklist

- Check the connection of the joint: The head of the double-head bolt and the red tag should be cut off.

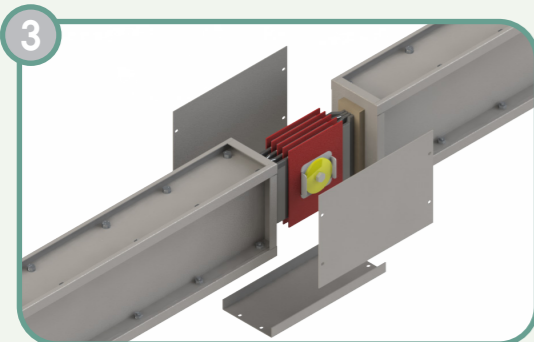

Assemble joint cover plates using M6 bolt. Top side should be open along with the direction where epoxy mixture is poured as the picture.

Checklist

- Assorting the edgewise, flatwise, and riser type cover while installation because the shapes of each joint covers are different.

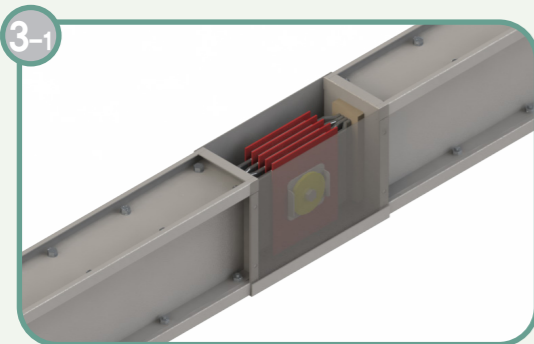

! Precaution

Make sure to remove all the dirt or moisture inside the joint cover as it can be a cause of deterioration of insulation or accident.



Be sure to keep the ambient temperature at 25°C or higher before mixing the epoxy resin and filler. When mixing the epoxy resin in a cool environment, be sure to cover the mixing container to keep warm. It is to maintain the temperature of the container at 25°C or higher. In order of filler, epoxy resin and hardener, add them into the mixing container, and mix it for 15 minutes using a hand drill. (Please contact our design team for information about how to maintain the temperature of the container when mixing the epoxy resin in a cool environment.)

Checklist

- The ambient temperature: 25°C or higher
- Mix filler, epoxy resin and hardener for 15 minutes

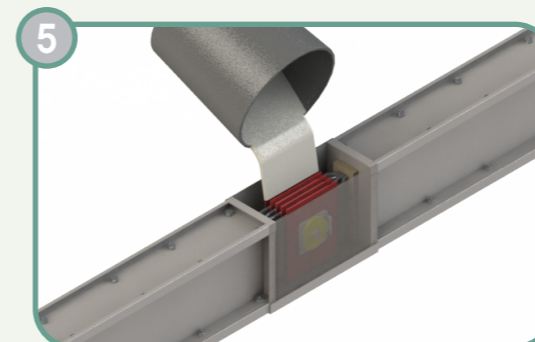

Pour the mixture into the molding flask. Maintain the ambient temperature at 25°C. When molding in a cool environment, cover the molding flask to keep warm to maintain the temperature at the molding flask. Remove foams on the surface of the mixture for about 1 hour. Mold only three joints out of a total of four, and continue molding the entire line following the same procedure. Wait for 8 hours, and check the function of the insulation by checking the insulation resistance. When it is normal, finish molding the remaining joint. (Please contact our design team for information about covering the container when molding the epoxy resin in a cool environment.)

Checklist

- Ambient temperature: 25°C or higher
- Removing foams on the surface of the mixture for 1 hour

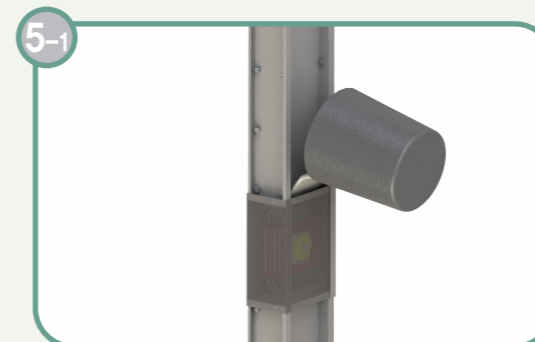

Perform the final inspection to check the performance of the joint.

Checklist

- Final inspection of the joint

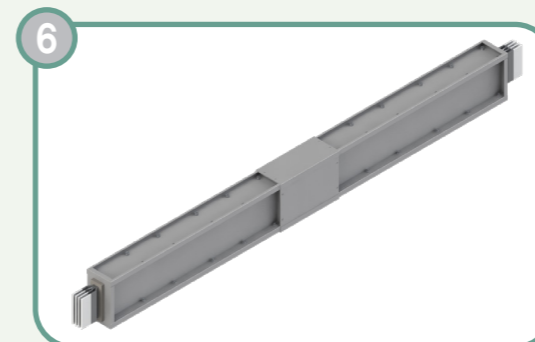

! As it is not possible to make any change caused by route change, mechanical shock or insulation defectiveness after pouring epoxy mixture, make sure to conduct a electrical and mechanical inspection to every piece beforehand.

CR-MV

LS Cable & System Busduct System Catalogue

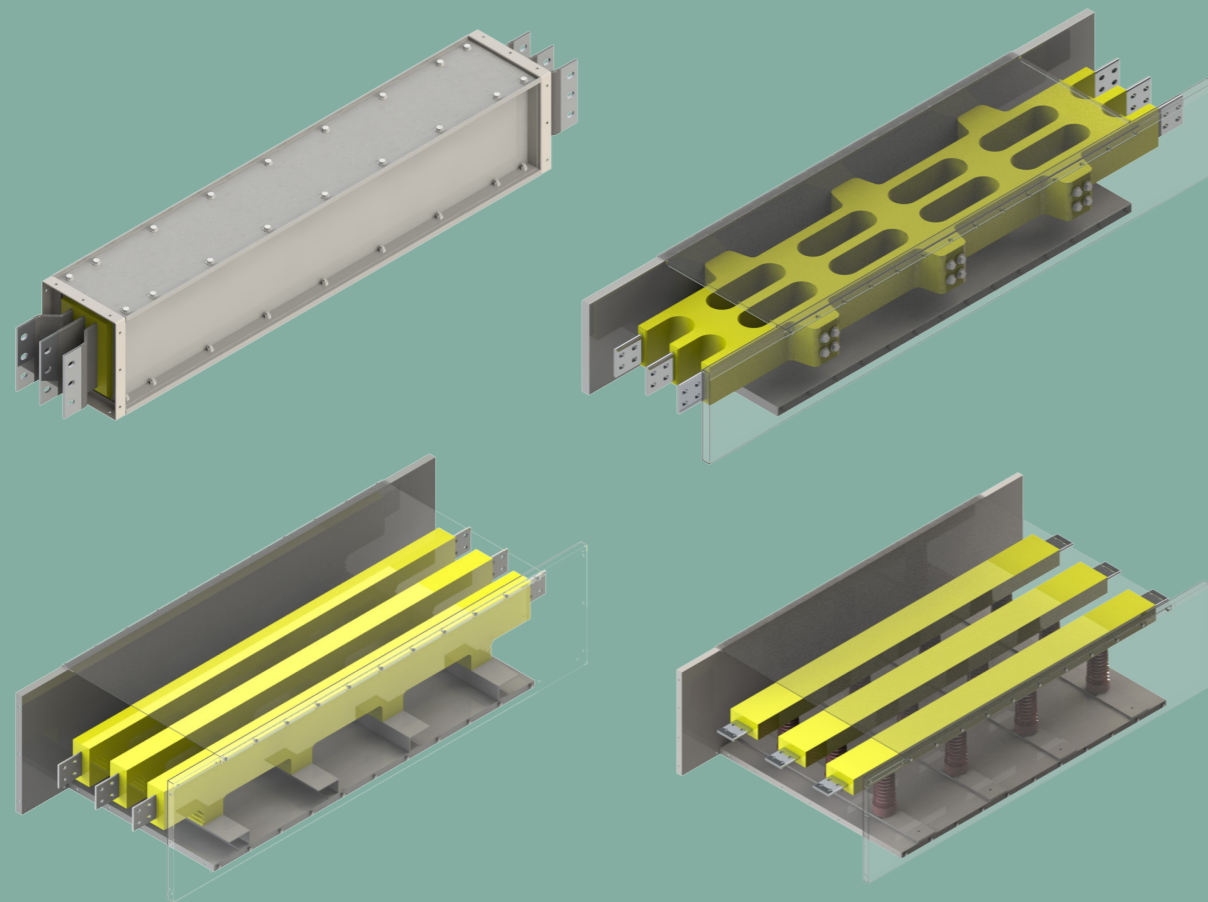

Contents

I. General Data	21
II. Component	
- CR-MV-I Feeder (7.2kV)	23
- CR-MV-I Fittings (7.2kV)	24
- CR-MV-II Feeder (17.5, 24kV)	25
- CR-MV-II Fittings (17.5, 24kV)	26
- CR-MV-III Feeder (36kV)	27
- CR-MV-III Fittings (36kV)	28
- Hanger	29
- Etc	30
III. Install Information	31
IV. Technical Data	35

I. General Data

Basic Structure

Unlike other typical high voltage (less than 36kV) air insulated type busducts, the CR-MV is completely covered with epoxy insulation molding including joint parts, allowing IP68 performance. The CR-MV is suitable for harsh service environment such as areas exposed to chemicals, flood risk...etc.

Applicable Standard: IEC 62271-200

Applicable Environment: Ambient temperature from -15°C to 35°C with humidity level less than 95%.

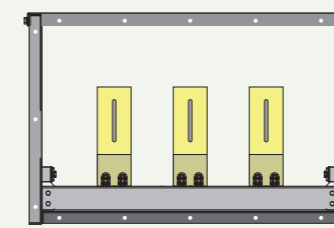

[CR-MV-3]

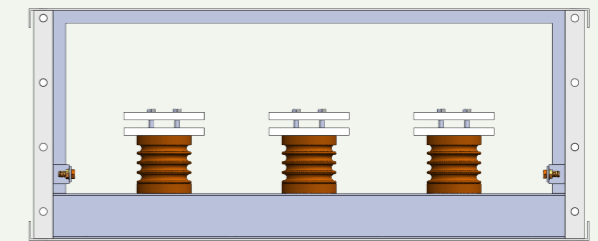

[NSPB-MV]

* Comparing the product of 24kV level same capacity, about 40% compact of CR-MV-3

Conductors	CR-MV	NSPB-MV
Insulation Type	Epoxy Resin Molding	Air Insulation
Installation Location	Special Plant (chemical plants, humid areas)	General Plants
Features	<ul style="list-style-type: none"> - Completely epoxy molded: IP68 - Water & dust proof, explosion proof, aseismatic certification - Suitable for harsh environment - Compact size compared to NSPB (approx. 60%) - Maintenance free - Need to consider weather condition (humidity) for joint installation work. - No risk for eddy current and corrosion 	<ul style="list-style-type: none"> - IP42 / IP54 / IP65 - Temperature difference may cause condensation inside NSPB. - Risk of short-circuit, ground fault due to condensation. - Periodic maintenance required due to corrosion, eddy current, short-circuit...etc.

Basic Structure

The CR-MV is compact in size compared to air insulated type busduct(NSPB) and provides high stability as it is completely covered with epoxy insulation molding. The CR-MV is designed for 36kV or less, between 1250A up to 5000A. The standard IP68 rating of the CR-MV is suitable for harsh service environment (dust, humid...etc.) both indoor and outdoor.

[CR-MV-I]

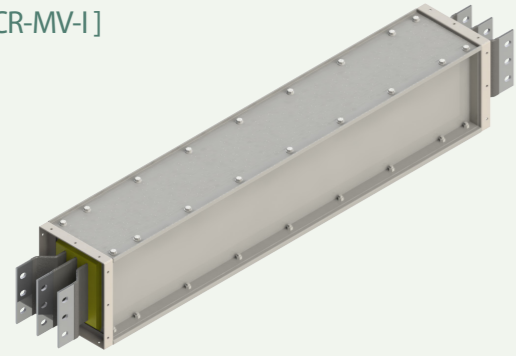

[7.2kV or less]

[CR-MV-II]

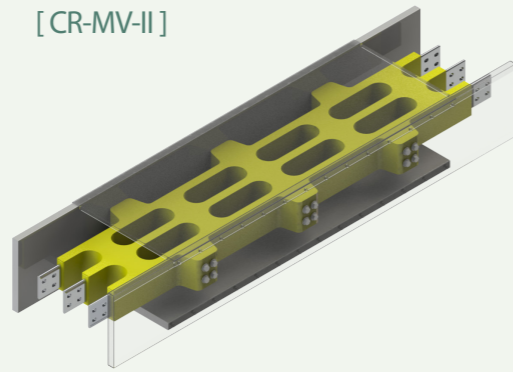

[17.5kV or less]

[CR-MV-III]

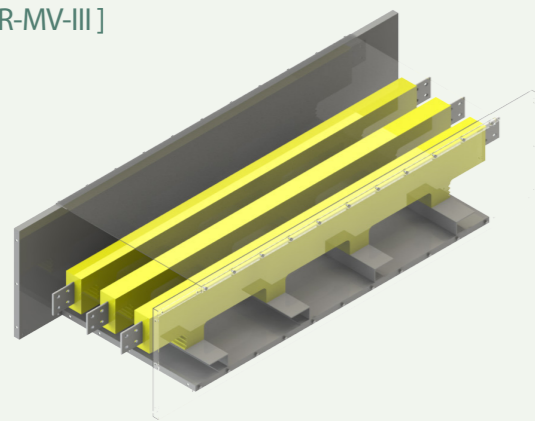

[24kV or less]

[CR-MV-IV]

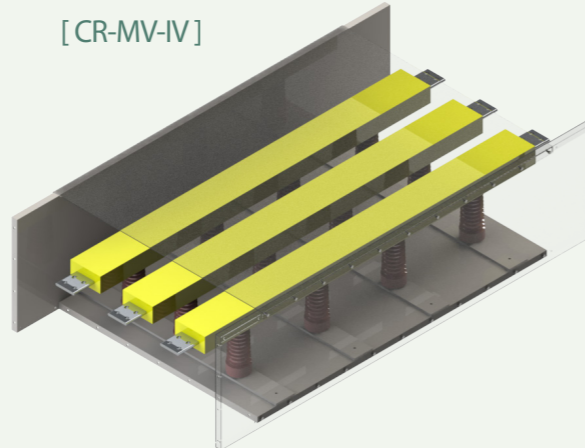

[36kV or less]

Type	Voltage	Phase & Wire	Conductor	Housing	Standard Length	Abbreviation
CR-MV-I	7.2kV or less	3P 3W	CU	AL	3m	3P3W 7.2kV CU CR MV-I 2000A IP68
CR-MV-II	17.5kV or less				2m	3P3W 17.5kV CU CR MV-II 2000A IP68
CR-MV-III	24kV or less				2m	3P3W 24kV CU CR MV-III 2000AIP68
CR-MV-IV	36kV or less				2m	3P3W 36kV CU CR MV-IV 2000A IP68

Note

High strength aluminum housing is applied for grounding, shielding and awning purpose.

Basic Structure of CR-MV-I (7.2kV)

Each conductors of CR-MV-I is insulated with Class B rated (130°C) epoxy powder coating and placed in metal housing. The space between conductors and metal housing is molded with epoxy resin providing improved performance compared to air insulated type busduct(NSPB) in terms of insulation performance, protection against mechanical impact and size.

Feeder

Housing (AL)
With Paint

Insulation-I
-Epoxy Powder Coating
(Class B 130°C)

Insulation-II
-Epoxy Resin

Conductor
(Copper)

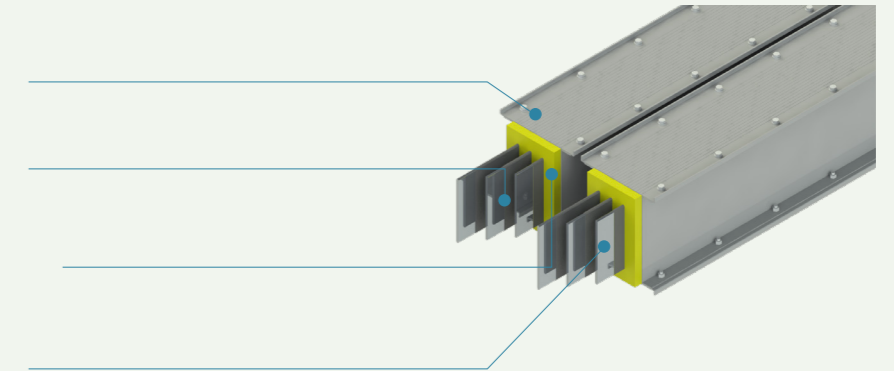

Section

[7.2kV]

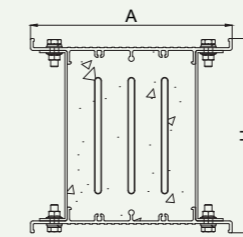

[1 Stack]

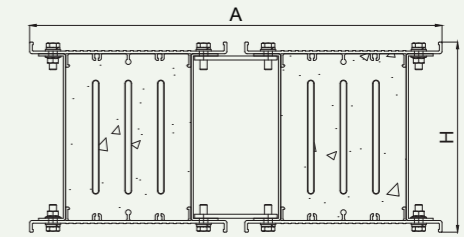

[2 Stack]

Ampere (A)	7.2kV								
	Conductor		Insulation		Housing (mm)		Short-circuit kA/1sec	Weight (kg/m)	
	Material	Stack	1st	2nd	Thickness	A			H
630/800	CU	1	Epoxy Coating	Epoxy Resin	3	220	127	50	-
1000						220	148		
1250						220	172		
1600						220	212		
2000						220	250		
2500		2				220	296		
3200						460	212		
4000						460	250		
5000						460	296		
						460	296		

* In case of considering aluminum conductor and/or other ampere rating than specified in above table, please contact our engineering team.

Fittings (7.2kV)

Various type of fittings including elbows and tees are designed to adapt to any change made to the direction of busduct installation. Specification of fittings are the same for all ampere ratings. Types and structures of fittings are as below.

Elbow
[Vertical]

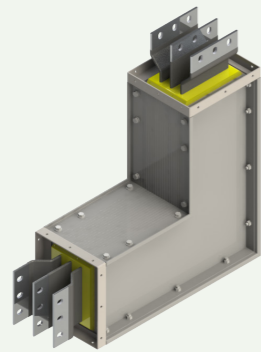

[Horizontal]

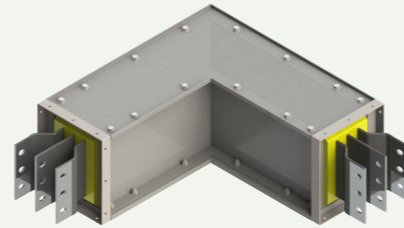

Offset
[Vertical]

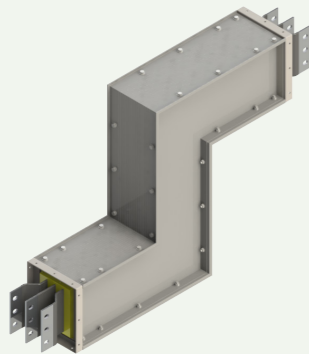

[Horizontal]

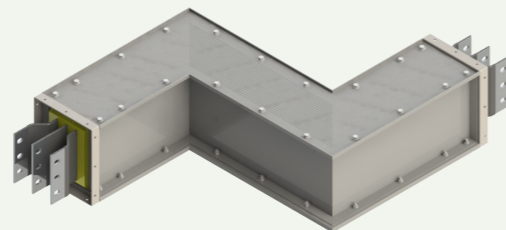

Tee
[Vertical]

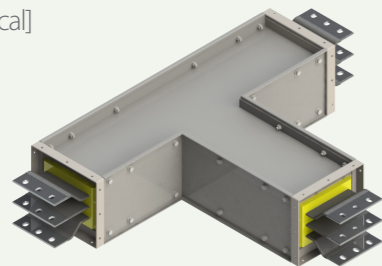

[Horizontal]

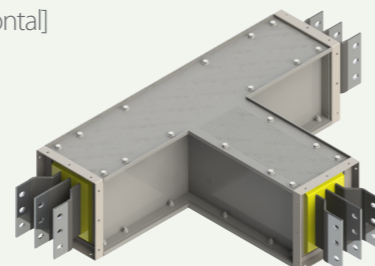

Combination

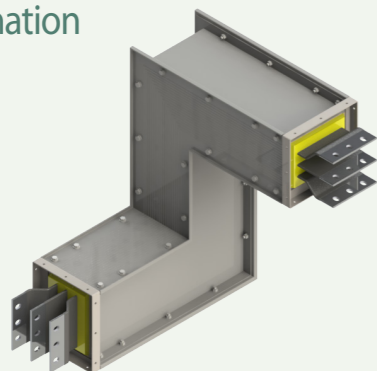

F.End

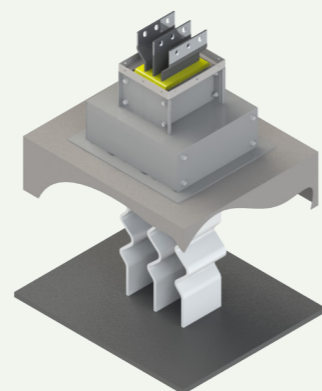

Basic Structure of CR-MV-II and III (17.5, 24kV)

Feeder

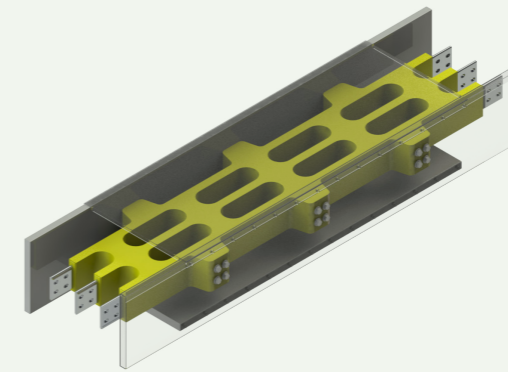

[~17.5kV]

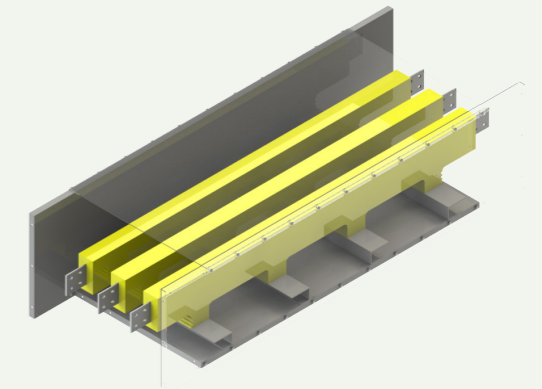

[~24kV]

Section

[17.5kV]

[24kV]

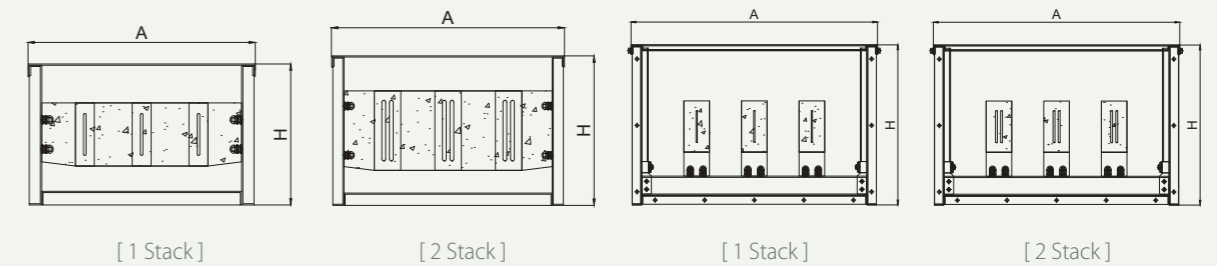

Ampere (A)	17.5kV						24kV						
	Conductor		A	H	Short-circuit (kA/1sec)	Weight (kg/m)	Conductor (mm)		A	H	Short-circuit (kA/1sec)	Weight (kg/m)	
	Material	Stack					Material	Stack					
630/800	CU	1	-	-	-	-	CU	1	-	-	-	-	
1000			540	-	-	-			770	460	40	142	
1250			540	335	30	119			770	460	40	143	
1600			540	335	40	127			770	500	40	147	
2000			540	335	132	155			770	500	40	155	
2500			540	335	143	163			770	500	40	163	
3200			540	395	199	222			900	500	40	222	
3600			540	395	207	248			900	525	40	248	
4000			2	615	395	286			262	900	525	40	262
5000				615	420	299			-	-	-	-	-

* In case of considering aluminum conductor and/or other ampere rating than specified in above table, please contact our engineering team.

Fittings (17.5, 24kV)

Various type of fittings including elbows and tees are designed to adapt to any change made to the direction of busduct installation. Specification of fittings are the same for all ampere ratings. Types and structures of fittings are as below.

Elbow

[Vertical]

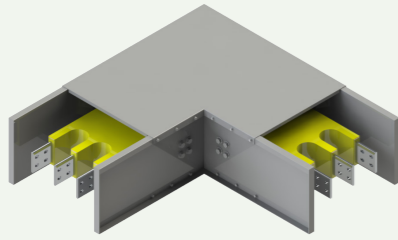

[Horizontal]

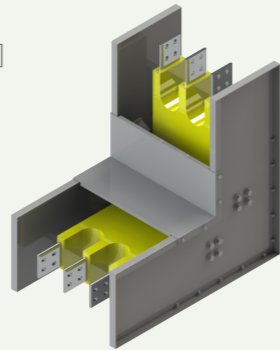

Offset

[Vertical]

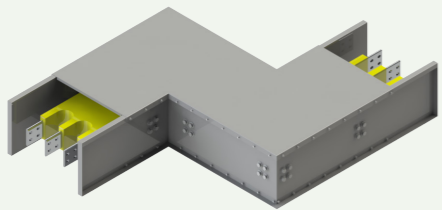

[Horizontal]

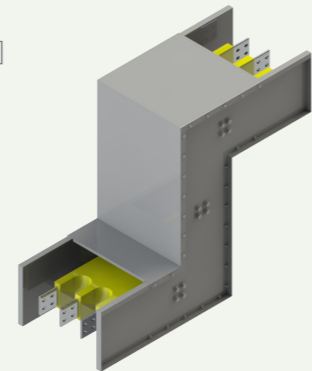

Tee

[Vertical]

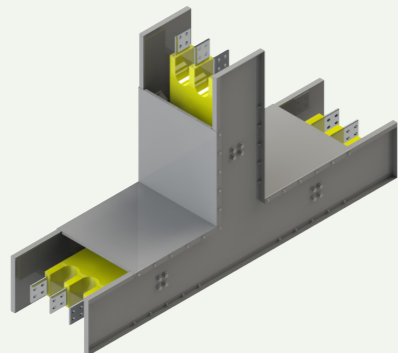

[Horizontal]

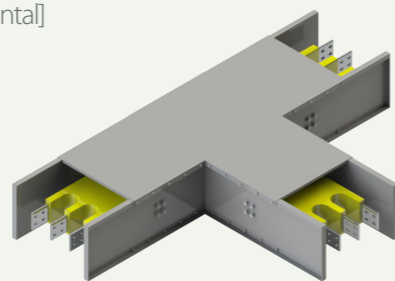

Combination

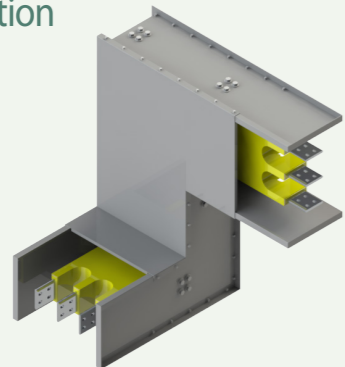

F.End

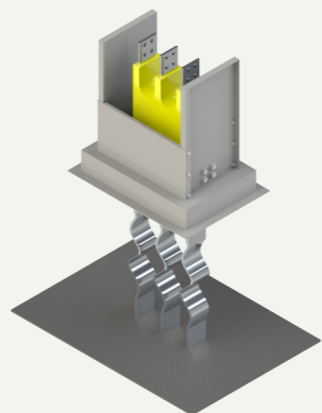

Basic Structure of CR-MV-IV (36kV)

Feeder

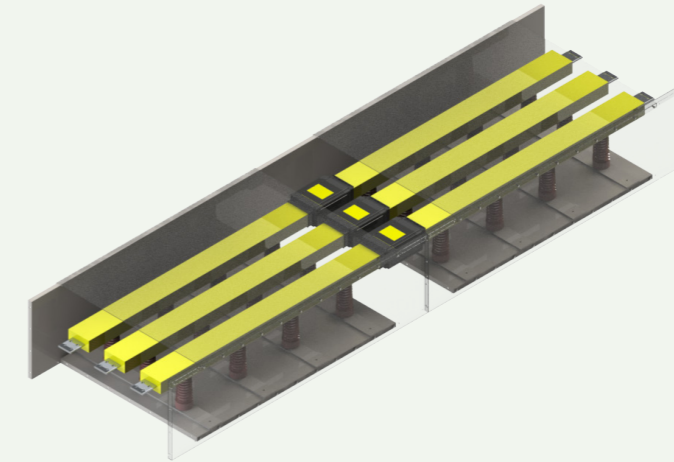

Section

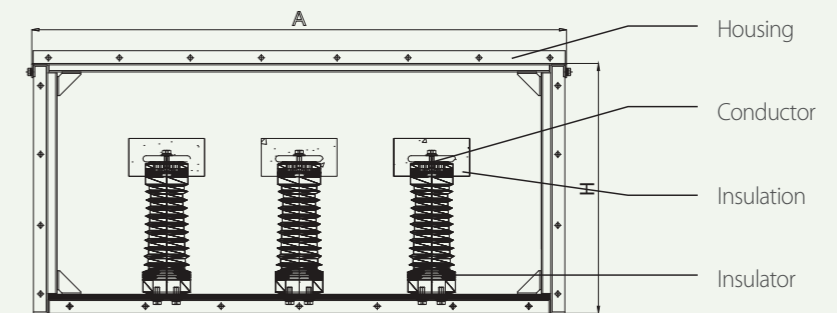

Ampere (A)	36kV						
	Conductor (mm)		Insulation		Housing (mm)		Weight (kg/m)
	Material	Stack	1st	2nd	A	H	
630/800	CU	1	Epoxy Coating (Option)	Epoxy Resin	1010	528	184
1000					1010	528	184
1250					1010	528	190
1600					1085	528	204
2000					1130	528	218
2500					1130	528	232
3200		2	-	-	-	-	-
3600			-	-	-	-	-
4000			-	-	-	-	-
5000			-	-	-	-	-

Fittings (36kV) – IV Type

Various type of fittings including elbows and tees are designed to adapt to any change made to the direction of busduct installation. Specification of fittings are the same for all ampere ratings. Types and structures of fittings are as below.

Elbow

[Vertical]

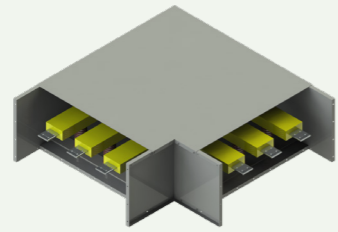

[Horizontal]

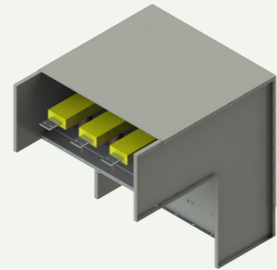

Offset

[Vertical]

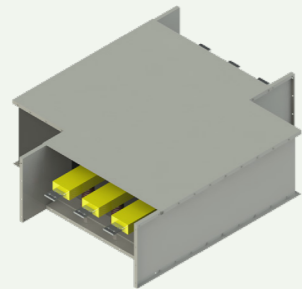

[Horizontal]

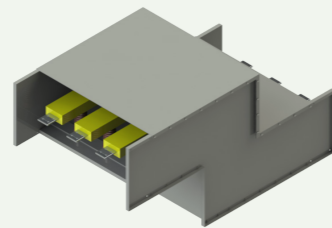

Tee

[Vertical]

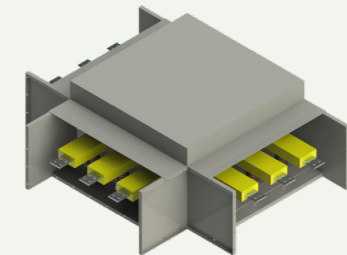

[Horizontal]

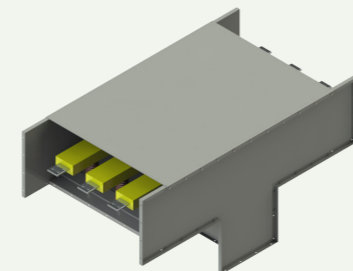

Combination

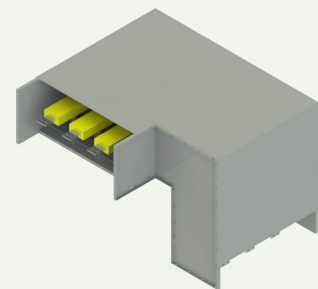

F.End

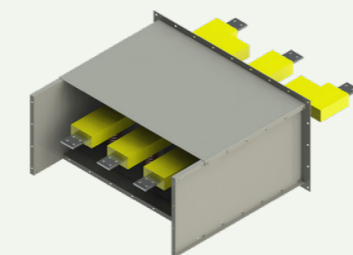

Hangers

Both horizontal and vertical hangers are available for the CR-MV depending on the installation environment.

Horizontal Hangers

The standard horizontal installation method of the CR-MV requires two supports for each product. The standard 3 meter busducts are designed to be installed at 1.5-meter intervals, and the space between the hangers should not surpass 2 meters at the most. (Please contact the design team for further information.)

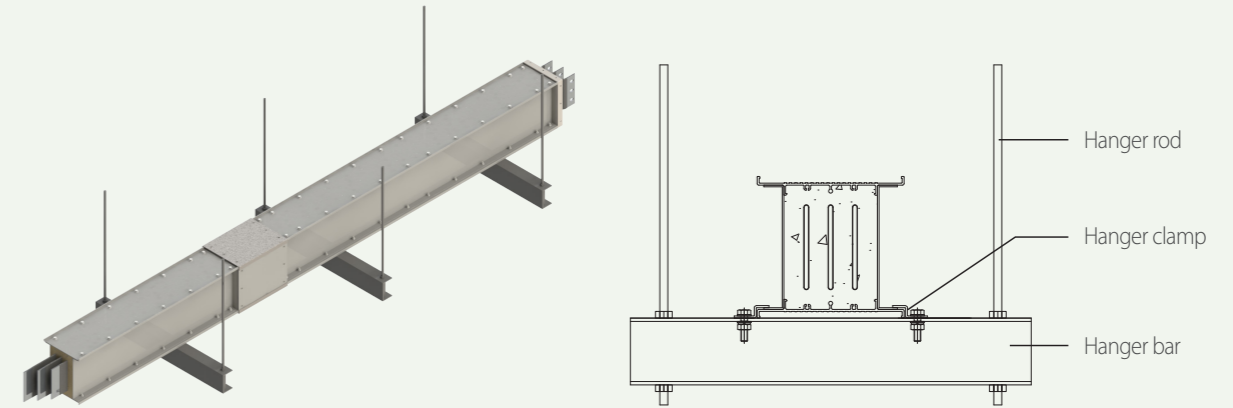

Vertical Hangers

For vertical installation of The CR-MV, install the vertical hangers first, and fix the Busducts on the hangers for better support.

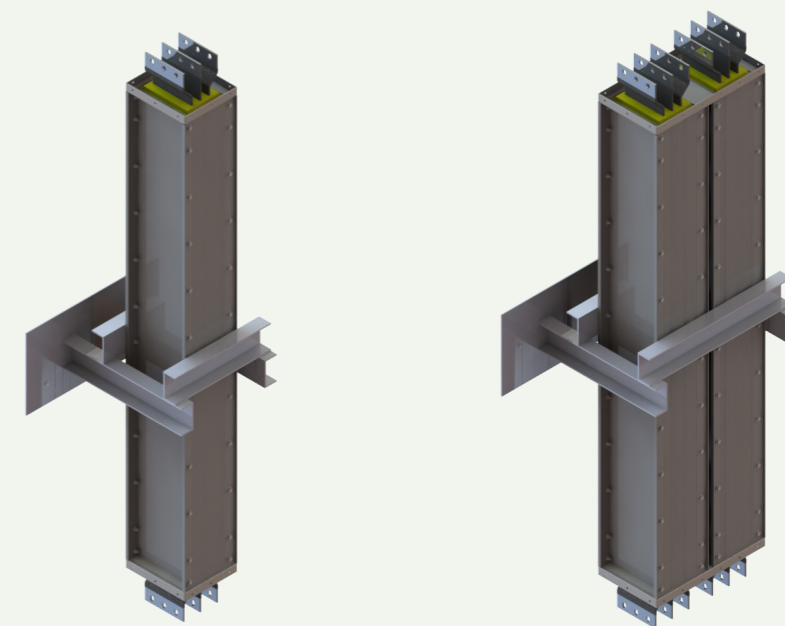

Etc.

Wall Flange

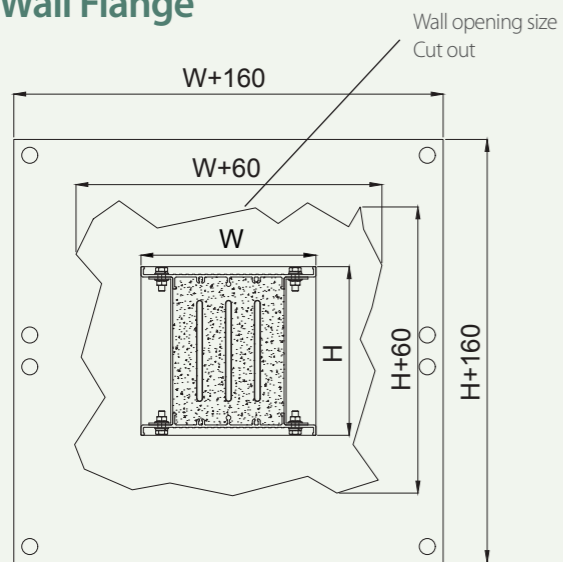

Floor Opening

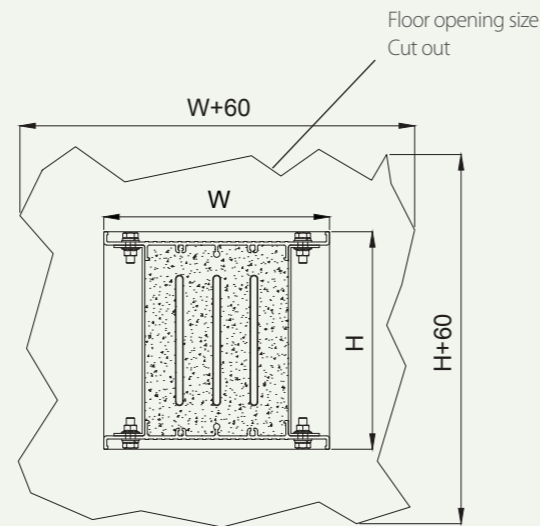

A wall flange is used to seal the gaps where busduct penetrates such as walls, ceilings and floors during installation. (Glass wool and fire forms can be provided as an option).

- W: The width of the product
- H: The height of the product

- W: The width of the product
- H: The height of the product

The required minimum distances from a wall for heat dissipation and maintenance

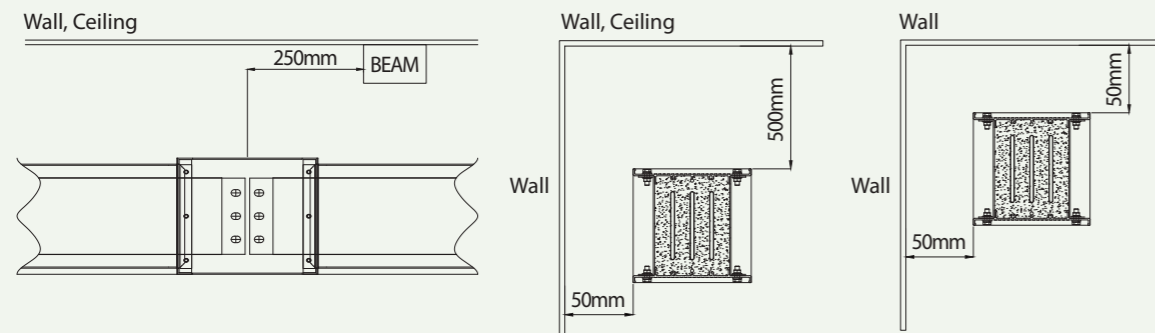

Joint Kit Installation for CR-MV-I (7.2kV)

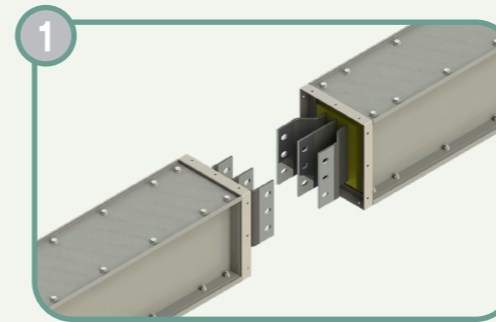

Before connecting the busducts, be sure to align them at the top and the bottom and the left and right as well as horizontally and vertically. Make sure that no foreign substances are found on the surface of joint parts and than connect the both side.

Checklist

- Alignment of Busducts
- No foreign substance to be found on the surface of the joint parts

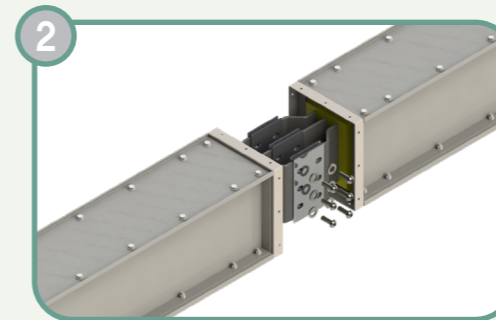

Connect and tighten each phase conductor using the provided connection busbars and bolts. After completion of connection works, verify the insulation performance (more than 1,000MΩ)

Checklist

- Verify whether the joint parts are correctly connected.

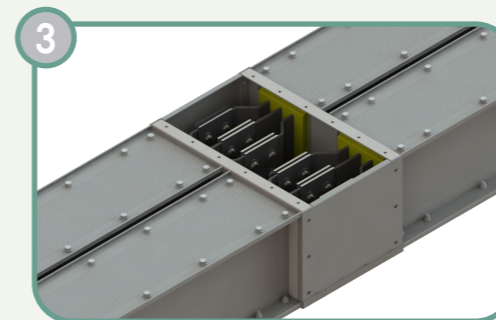

Assemble the joint covers (both sides and the bottom) using M6 bolts. In case of horizontal busduct installation, do not assemble the top side of joint cover. In case of vertical installation of busduct, assemble all the joint covers (top, bottom, left and right).

As the type of joint cover is different for vertical and horizontal installation, close attention is required to apply proper joint cover type(Refer to the figure 5-2 and 5-3 below).

Checklist

- Installation of proper joint cover for horizontal / vertical busduct installation.

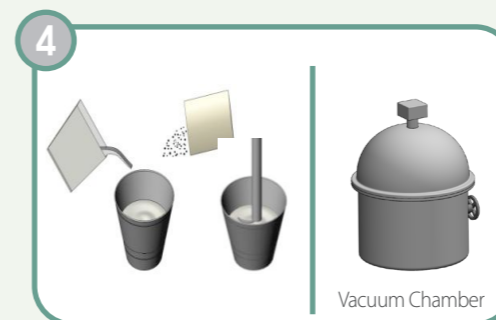

Be sure to check the ambient temperature before mixing the mixture (epoxy resin, hardener, filler). In case of mixing in a cool environment, be sure to cover the mixing container to keep it warm. Pour the filler, epoxy resin and hardener in sequential order and mix them for approximately 10 minutes using hard drill. (Please contact engineering team for the details of mixing procedure in cool environment).

Checklist

- Once mixing is completed, pour the mixture into the provided vacuum chamber and whisk it for 10 minutes to remove foams.

! Note

Please be sure to remove all foreign substances and humidity in joint parts or it may cause degradation of insulation performance and other accidents.

Joint Kit Installation for CR-MV-II, III and IV (17.2 ~ 36kV)

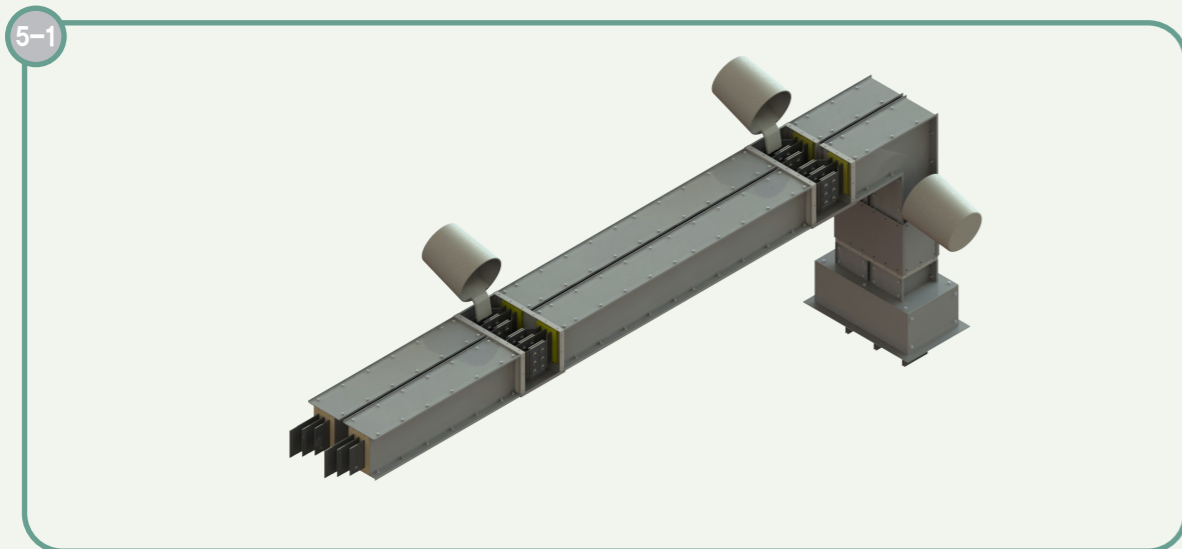

Once removal of foams is completed, pour the mixture into the connection parts. After completion of molding, remove the bubbles on the top of the molding parts for approximately 1 hour.

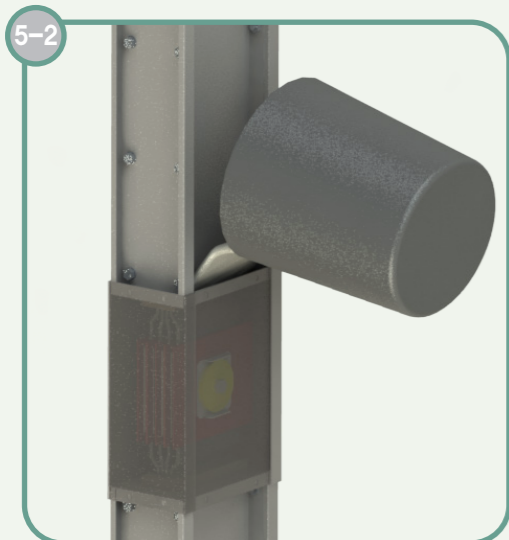

[Pouring work for Vertical Installation]

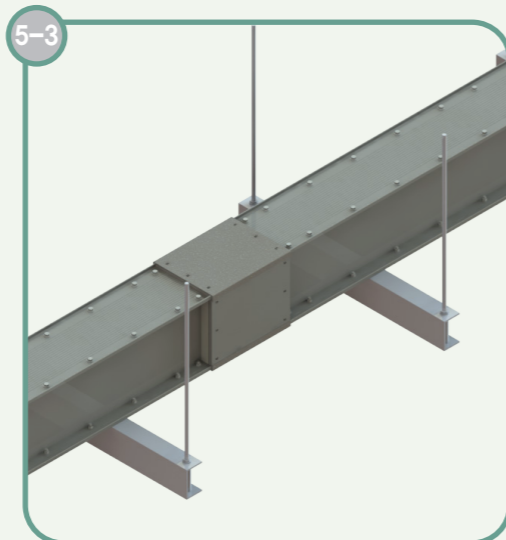

[Pouring work for horizontal Installation]

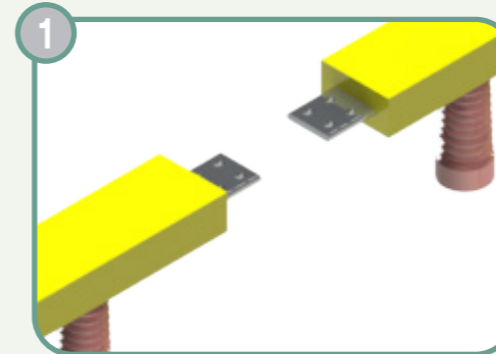

Before connecting the busducts, be sure to align them at the top and the bottom and the left and right as well as horizontally and vertically. Make sure that no foreign substances are found on the surface of joint parts and than connect the both side.

Checklist

- Alignment of Busducts
- No foreign substance to be found on the surface of the joint parts

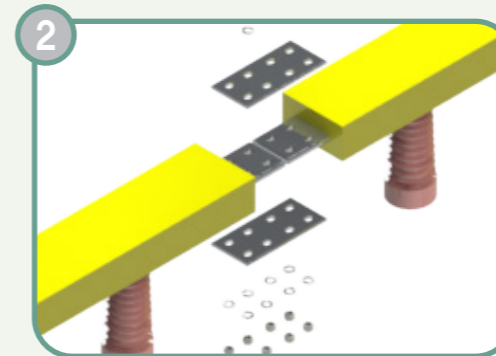

Connect and tighten each phase conductor using the provided connection busbars and bolts.

Checklist

- Verify whether the joint parts are correctly connected.

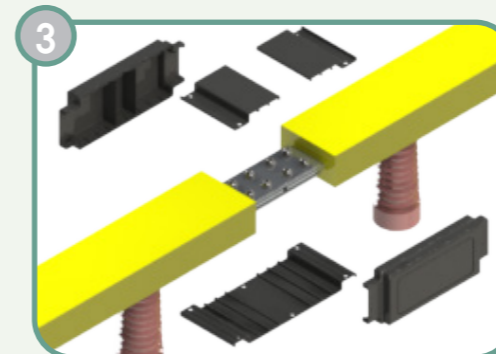

Assemble the plastic molding flask (4 pieces: top, bottom and left, right)

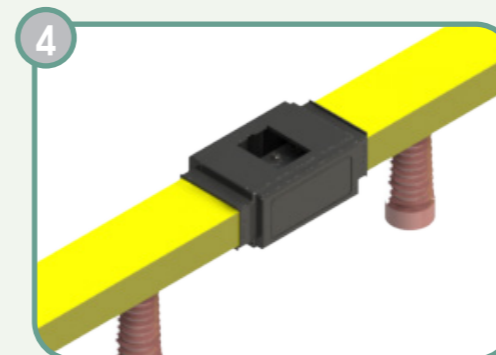

Check whether the assembled plastic molding flask is in firm contact with the busduct and is correctly centered over the joint.

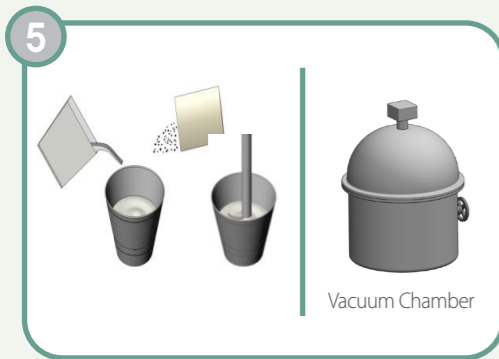

Be sure to check the ambient temperature before mixing the mixture (epoxy resin, harder, filler). In case of mixing in a cool environment, be sure to cover the mixing container to keep it warm. Pour the filler, epoxy resin and harder in sequential order and mix them for approximately 10 minutes using hard drill. (Please contact engineering team for the details of mixing procedure in cool environment).
Once mixing is completed, pour the mixture into the provided vacuum chamber and whisk it for 10 minutes to remove foams.

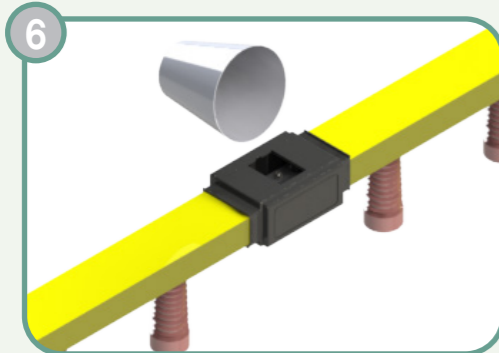

Once removal of foams is completed, pour the mixture into the connection parts. If mixture pouring work to be carried out in cool environment, be sure to take necessary measures to keep the molding flask warm. After completion of molding, remove the bubbles on the top of the molding parts for approximately 1 hour. Proceed the same works for all the joint parts. 8 hour after completion of molding work, check the insulation performance and complete the molding work if no abnormality is found.

Checklist

- Verify the time required for installation work depending on the ambient temperature.

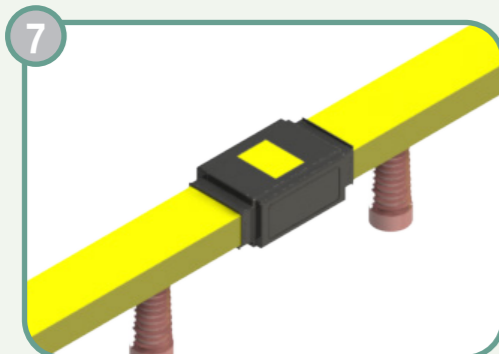

Do not remove the molding flask and proceed final verification whether epoxy mixtures are fully poured inside the flask.

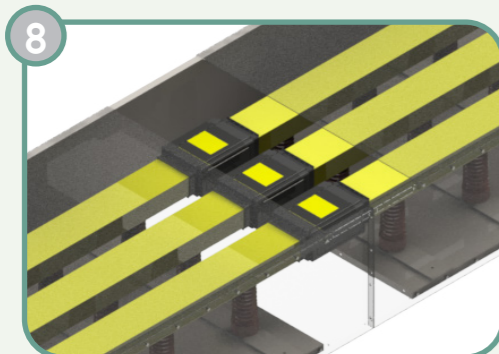

Assemble the joint cover of housing and complete the installation work.

Impedance and Heating Value

Conductor	Voltage (kV)	Ampere (A)	Impedance [$10^{-4}\Omega/m$]			Voltage Drop (V/100m)				Heating Value (Wh)
			R	X	Z	0.7	0.8	0.9	1	
CU	7.2	1000	4.72	9.71	10.8	10.77	9.9	9.04	8.17	165.67
		1250	3.52	8.02	8.76	10.55	9.57	8.60	7.63	192.30
		1600	2.53	6.26	6.75	10.11	9.08	8.04	7.01	225.10
		2000	2.02	5.19	5.57	10.30	9.20	8.11	7.01	280.55
		2500	1.64	4.30	4.60	10.57	9.42	8.27	7.12	355.74
		3200	1.43	3.13	3.44	10.75	9.81	8.86	7.92	505.15
		4000	1.15	2.59	2.83	10.94	9.94	8.94	7.93	633.11
	17.5	5000	0.93	2.15	2.34	11.21	10.15	9.09	8.04	803.11
		1250	4.64	15.62	16.29	17.18	14.80	12.42	10.04	254.70
		1600	3.24	15.48	15.82	19.16	15.76	12.37	8.98	289.55
		2000	2.54	15.35	15.56	22.12	17.68	13.25	8.81	353.09
		2500	1.85	15.08	15.19	25.21	19.48	13.75	8.02	397.91
		3200	1.44	12.27	12.35	25.99	19.98	13.98	7.98	507.85
		4000	1.26	12.19	12.25	31.43	23.85	16.27	8.70	690.52
24	4000	0.83	8.2	8.24	21.05	15.94	10.83	5.73	455.91	
	5000	0.63	6.21	6.24	19.98	15.15	10.33	5.50	548.50	
	1000	7.45	21.19	22.46	20.05	17.67	15.29	12.91	263.60	
	1250	6.05	21.08	21.93	22.86	19.61	16.35	13.10	333.30	
	1600	4.64	17.66	18.26	23.68	20.07	16.46	12.86	417.30	
36	2000	2.54	17.39	17.57	24.24	19.10	13.95	8.81	353.09	
	2500	1.85	17.12	17.22	27.86	21.24	14.63	8.02	397.91	
	630	7.45	23.26	24.43	13.31	11.58	9.86	8.13	104.62	
	800	7.45	23.26	24.43	16.9	14.71	12.52	10.33	168.71	
	1000	6.05	23.15	23.93	19.36	16.40	13.44	10.48	213.31	
	1250	3.05	22.23	22.44	19.07	14.92	10.76	6.61	165.80	
	1600	2.44	21.04	21.18	22.22	17.06	11.91	6.75	215.75	
2000	2.13	20.35	20.46	26.31	19.99	13.68	7.37	293.82		
2500	1.75	20.15	20.23	31.48	23.51	15.54	7.57	374.60		

* Possible to calculate AC resistance with the value of calculated temperature and frequency.

Electrical conductivity AL 35380000 S/m
CU 58000000 S/m

Calculated temperature 20°C

Using frequency 60hz

GLOBAL NETWORK

More than 60 Factories,
Sales and Production Sites
in 20 Countries.

- Factory
- Sales office
- Branch office



KOREA



Gumi Plant
EHV / MV / LV cable
UTP, Coaxial cable
SCR, Magnet wire
Overhead cable, Bus duct



Indong Plant
Optical fiber
Optical cable



Donghae Plant
Submarine cable
Industrial specialty cable

CHINA



LSHQ(Yichang)
EHV / MV / LV cable
Industrial specialty cable



LSCW(Wuxi)
Industrial devices cable
Automotive cable
Harness & module
Aluminum, Bus duct

VIETNAM



LS-VINA(Haiphong)
EHV / MV / LV cable
SCR, ACSR
Overhead cable



LSCV(HO Chi Minh)
MV / LV cable
UTP, Optical cable
Overhead cable

INDIA



LSCI(Bawal)
EHV / MV / LV cable
Coaxial cable
Overhead cable

USA



LSCUS(Tarboro)
MV / LV cable
Control, Instrument cable

POLAND



LS EV Poland./LSCP (Dzierzoniow)
Automotive battery components
Optical cable